

PLANTA SEGUNDO PISO N+3.42

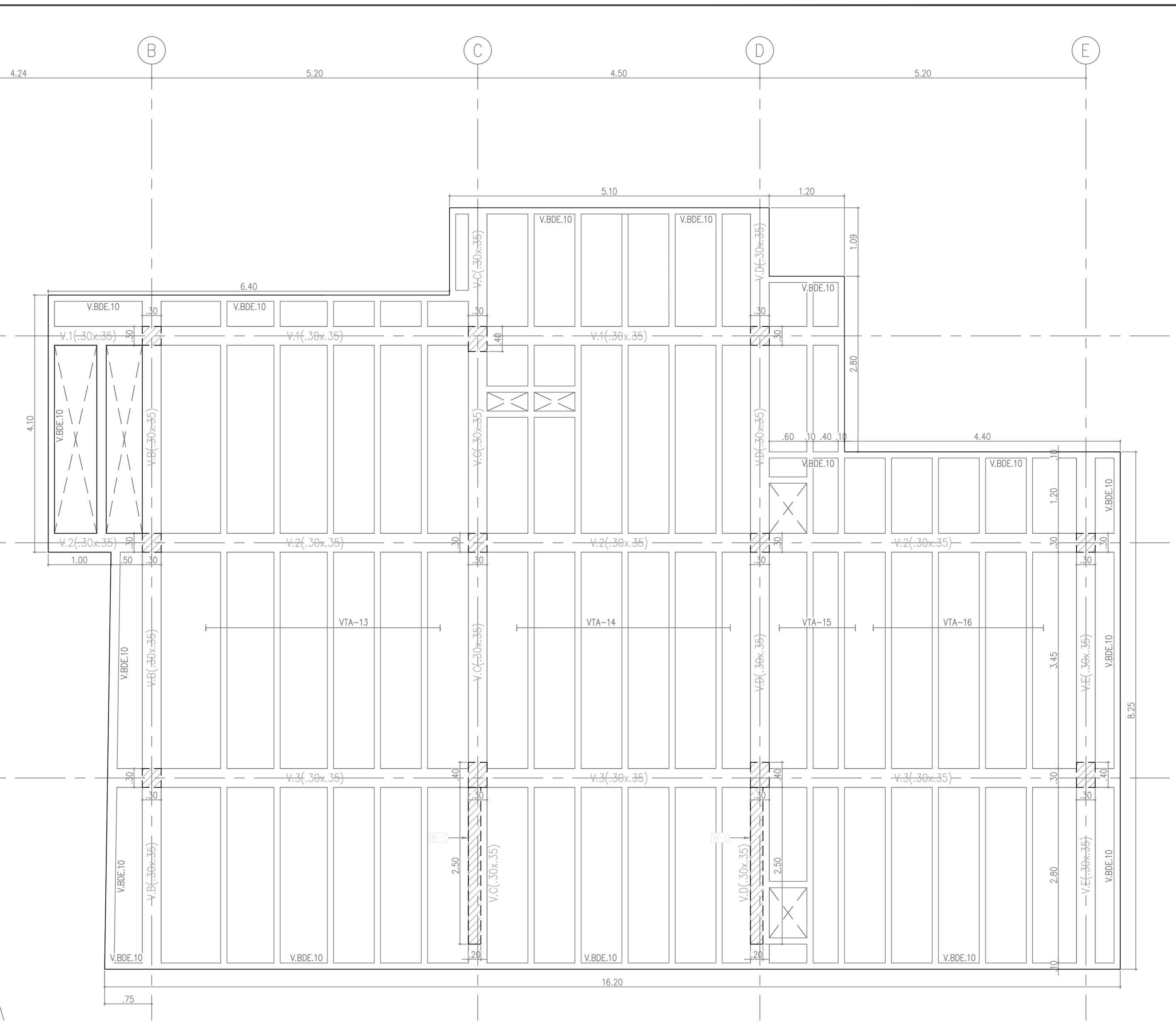

PLANTA DE CUBIERTA N+6.87

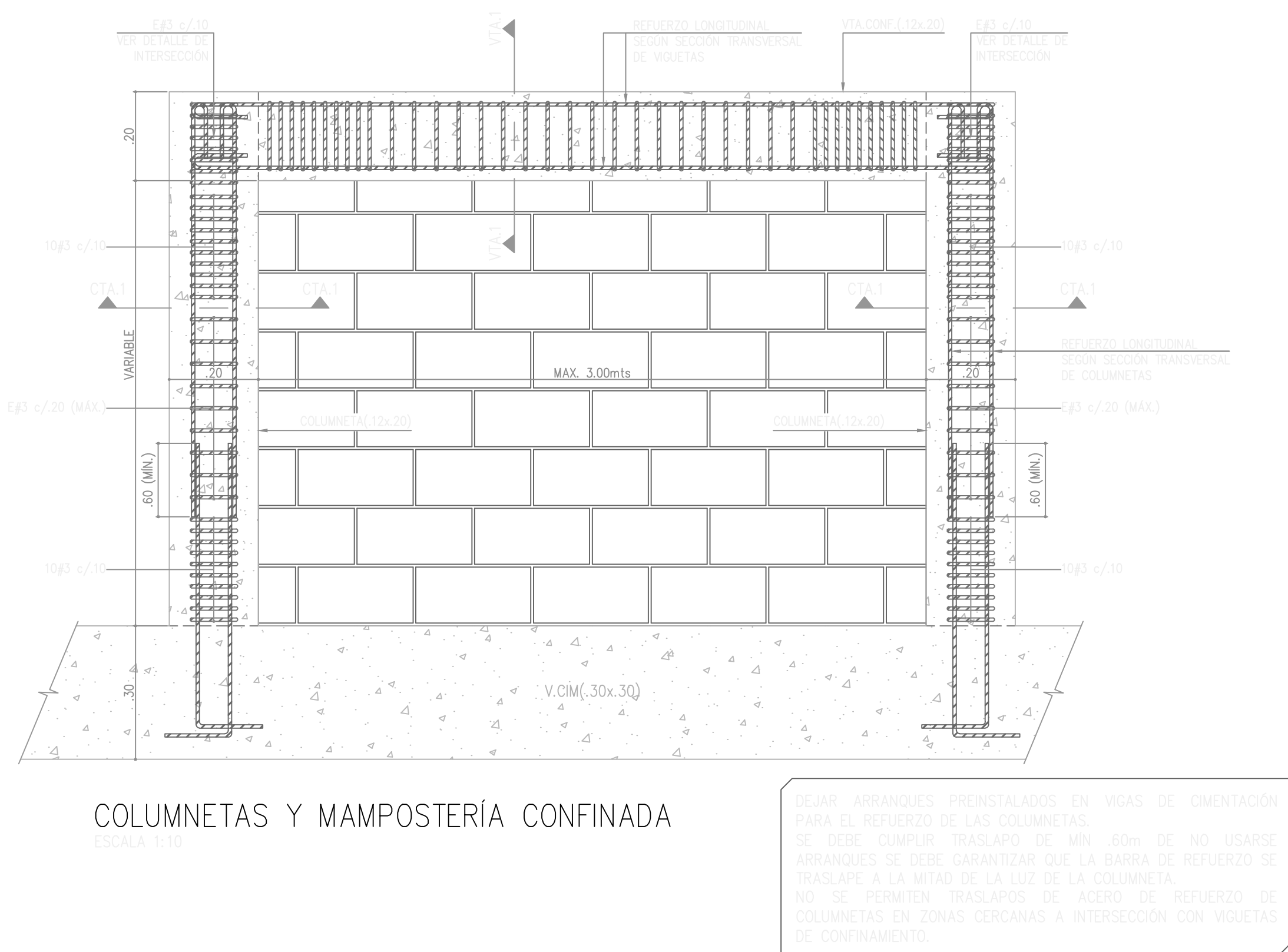

COLUMNETAS Y MAMPOSTERÍA CONFINADA
ESCALA 1:10

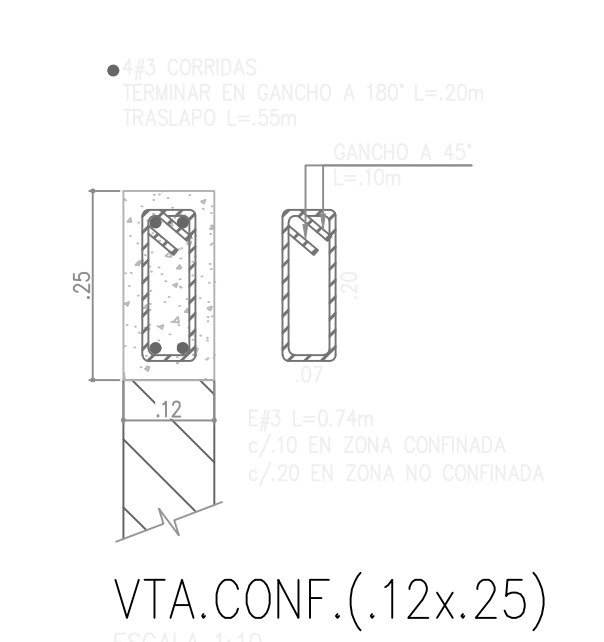

VTA.CONF.(.12x.25)
ESCALA 1:10

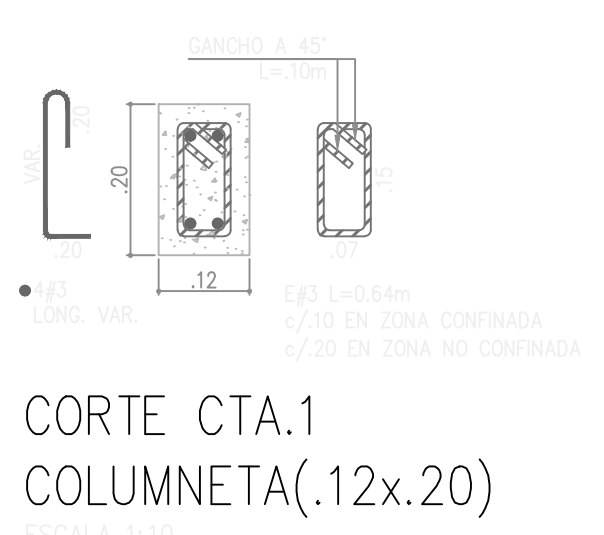

CORTE CTA.1
COLUMNETA(.12x.20)
ESCALA 1:10

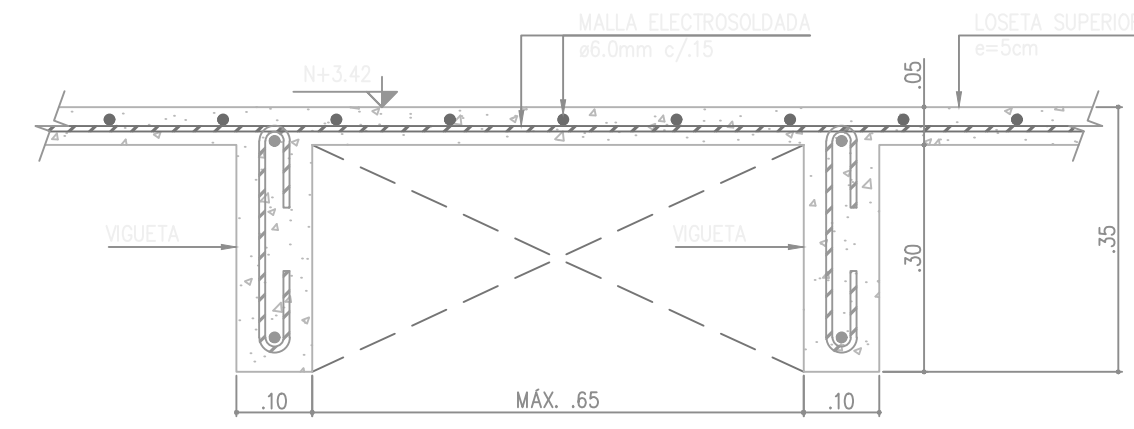

PLACA ALIGERADA h=.35m
DETALLE TÍPICO
ESCALA 1:10

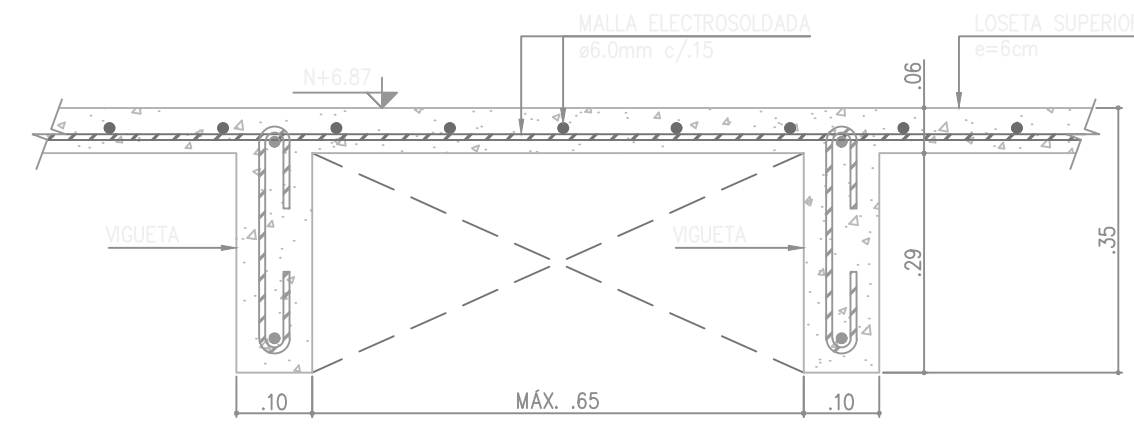

PLACA ALIGERADA h=.35m
EN CUBIERTA
ESCALA 1:10

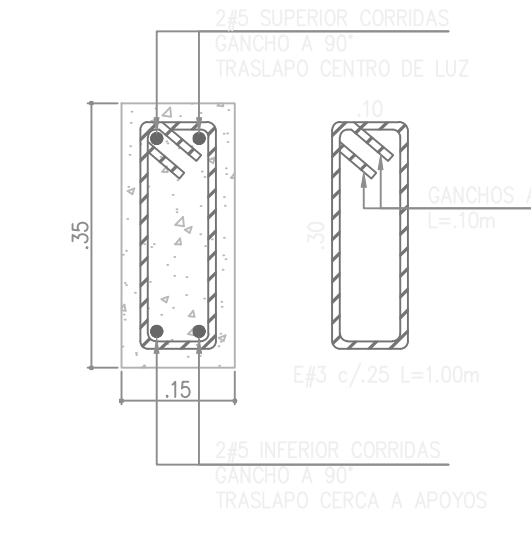

V.BDE.(.15x.35)
ESCALA 1:10

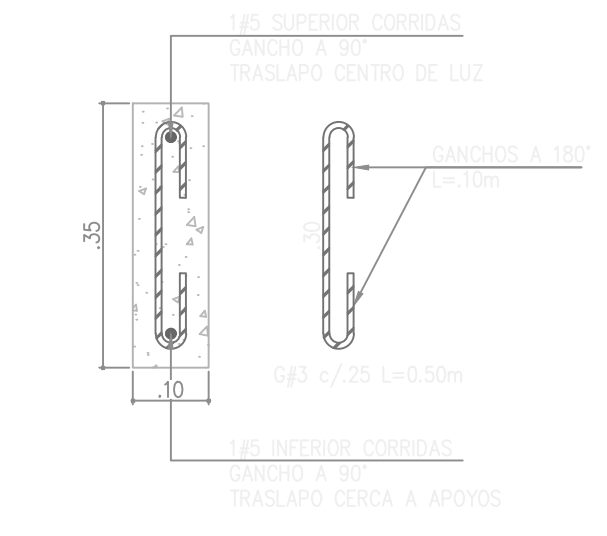

RIOSTRA/V.BDE.(.10x.35)
ESCALA 1:10

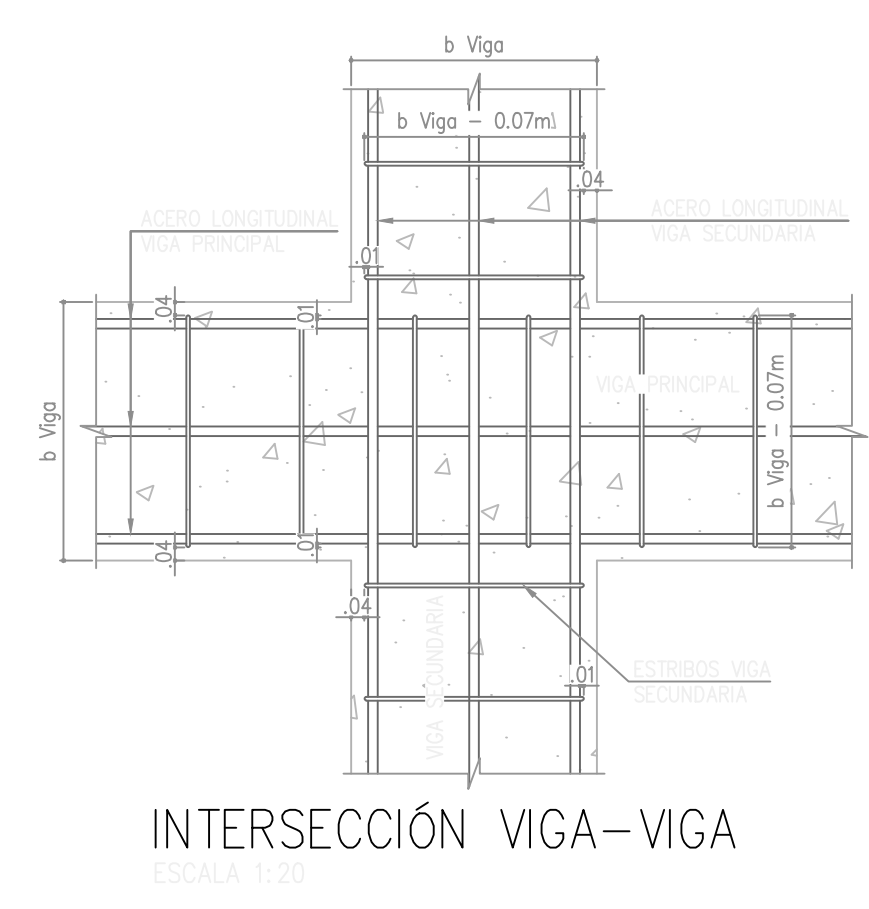

INTERSECCIÓN VIGA-VIGA
ESCALA 1:20

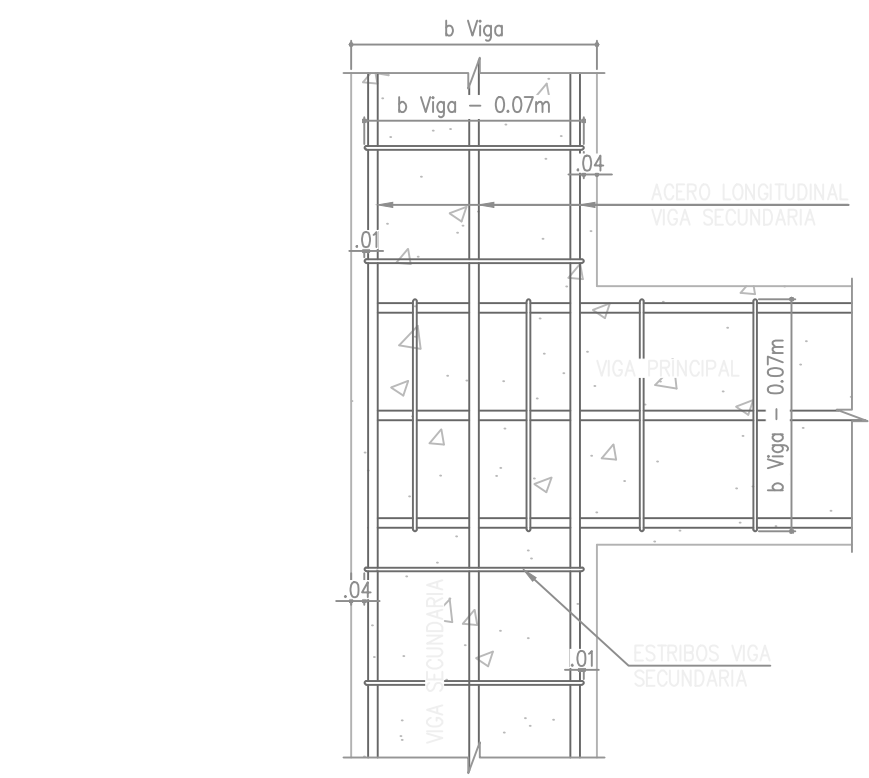

INTERSECCIÓN VIGA-VIGA
CONDICIÓN DE BORDE
ESCALA 1:20



INTERSECCIÓN VIGA-COLUMNA
ESCALA 1:20

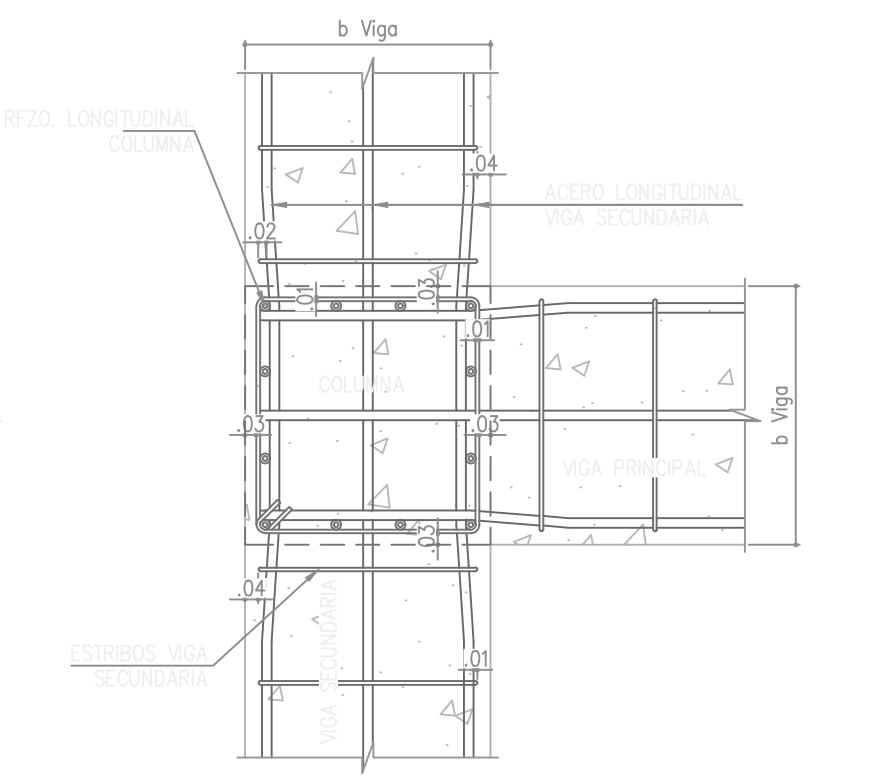

INTERSECCIÓN VIGA-COLUMNA
CONDICIÓN DE BORDE
ESCALA 1:20

PROYECTO VIVIENDA VADUZ LOTE 28 CONDOMINIO VALLE DE VADUZ PROPIEDAD HORIZONTAL FLORIDABLANCA - SANTANDER	
PROPIETARIO CESAR AUGUSTO SANDO RIVERA	
REVISIONES	
DISEÑADOR JORGE FABIAN DELVEZ MAREYAR NAVA 180000 - TORREO 370	
DIBUJANTE ANDERSON OMAR GUARTE CELIS	
CONTIENE PLANTA N+3.42 PLANTA DE CUBIERTA N+6.87 DETALLES GENERALES	
FECHA 26 DE DICIEMBRE DE 2023	ESCALA RECORRIDAS
PLANO EST_02	