



N.º DE ELEMENTO	NOMBRE DE PIEZA	MATERIAL	CANTIDAD
1	CAMISA	AISI 304	1
2	TOBERA	AISI 304	1
3	Bulkhead	AISI 304	1
4	LINEAR	PLA	1
5	AISLANTE	Cartón	3
6	GRANO		3
7	O-ring 2-338		3
8	O-ring 2-042		2
9	B18.3.1M - 5 x 0.8 x 8 Hex SHCS -- 8NHX		16

Universidad Industrial de Santander 	ESCUELA DE INGENIERIA MECANICA	
ESCALA: 1:3 	MOTOR DIBUJADO POR: SCUA- Orion Mision, Propulsion Team	
FORMATO A3	MATERIAL:	HOJA 1/8
UNIDADES: mm	FECHA: 23/07/2022	PL N° 00-01-00

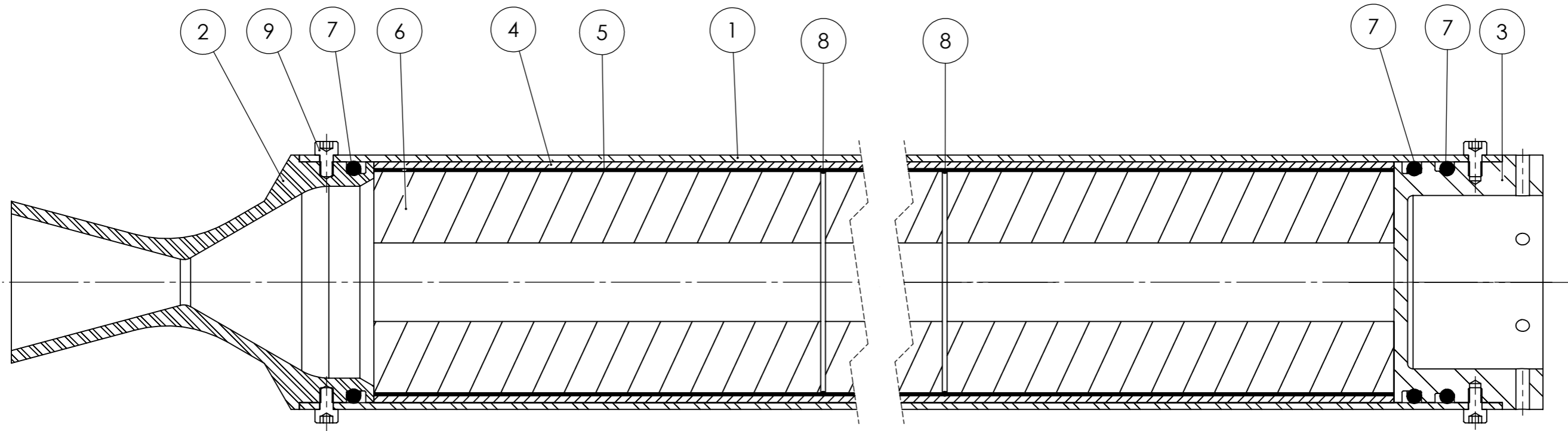

N.º DE ELEMENTO	NOMBRE DE PIEZA	MATERIAL	CANTIDAD
1	CAMISA	AISI 304	1
2	TOBERA	AISI 304	1
3	Bulkhead	AISI 304	1
4	LINEAR	PLA	1
5	ASLANTE	Cartón	3
6	GRANO		3
7	O-ring 2-338		3
8	O-ring 2-042		2
9	B18.3.1M - 5 x 0.8 x 8 Hex SHCS -- 8NHX		16

Universidad Industrial de Santander



ESCUELA DE INGENIERIA MECANICA

ESCALA: 3:5

MOTOR



DIBUJADO POR:  
SCUA- Orion Mision, Propulsion Team

FORMATO A3

MATERIAL:

HOJA 2/8

UNIDADES:  
mm

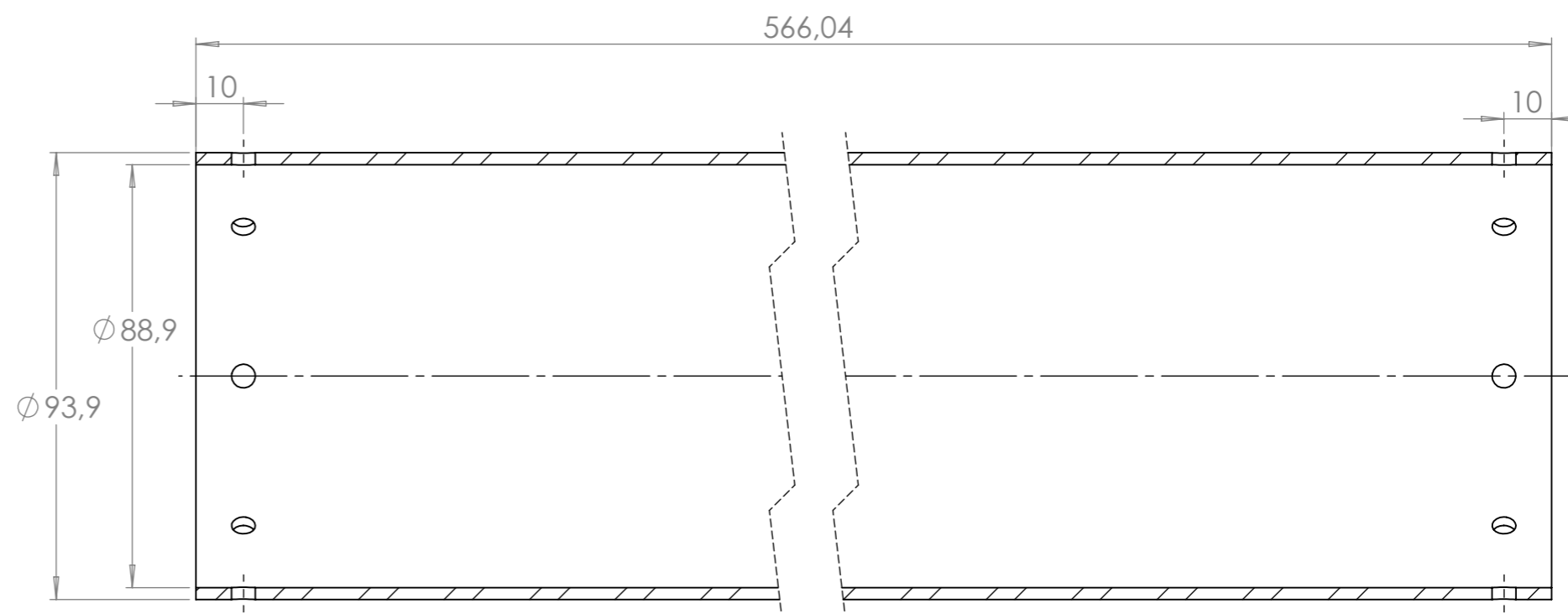
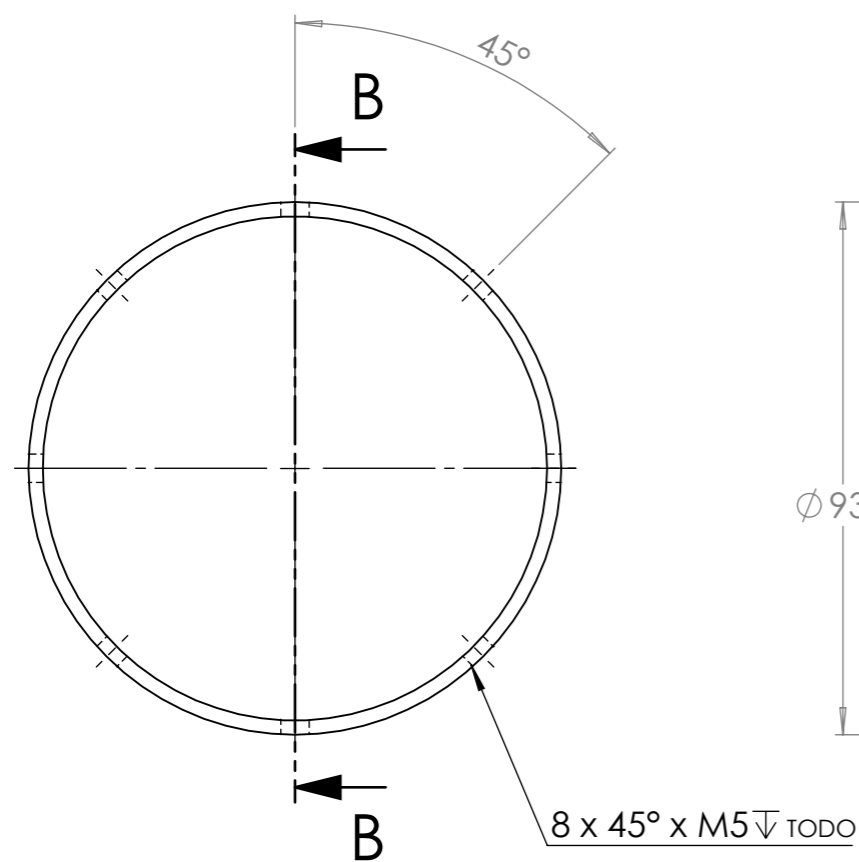

FECHA:  
23/07/2022

PL N° 00-01-00



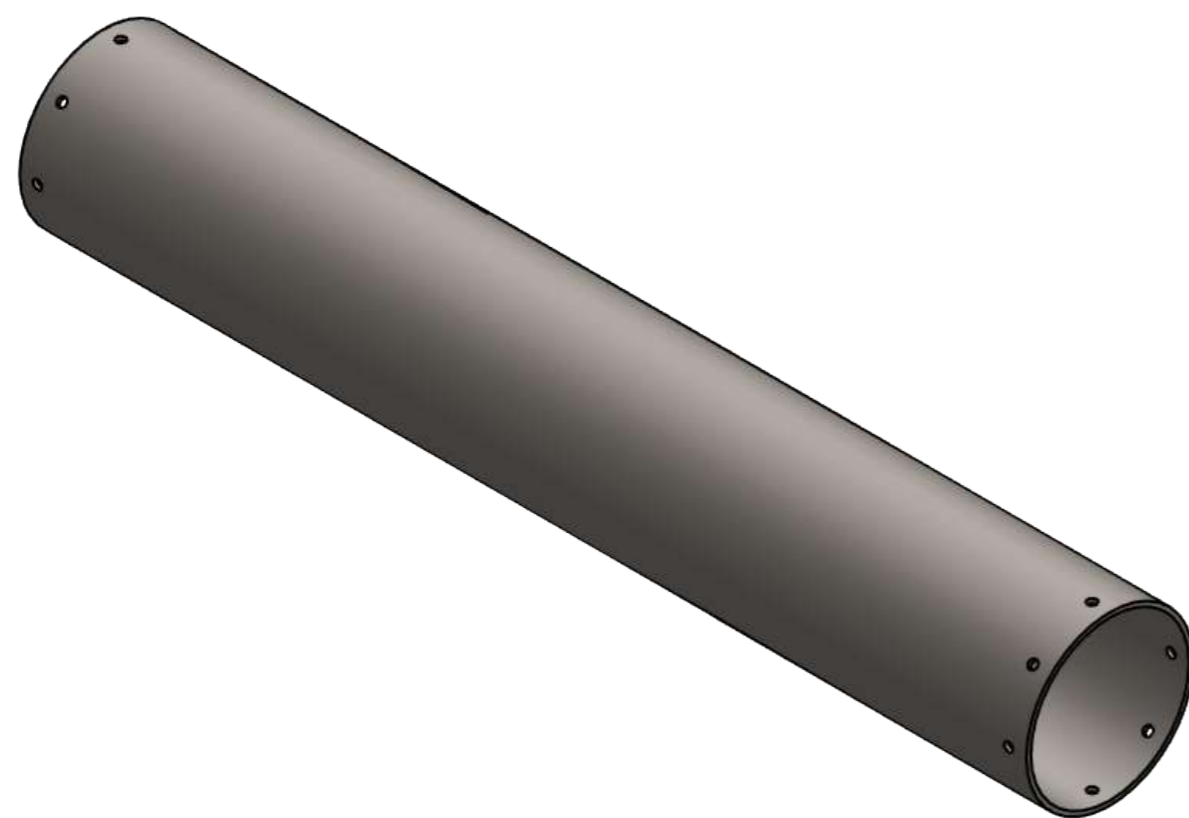

SECCIÓN B-B



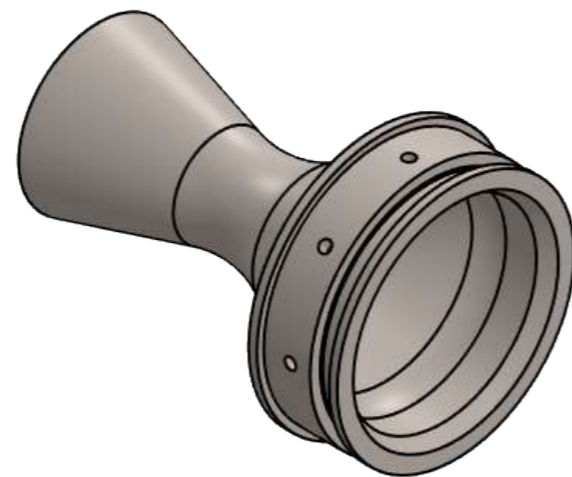
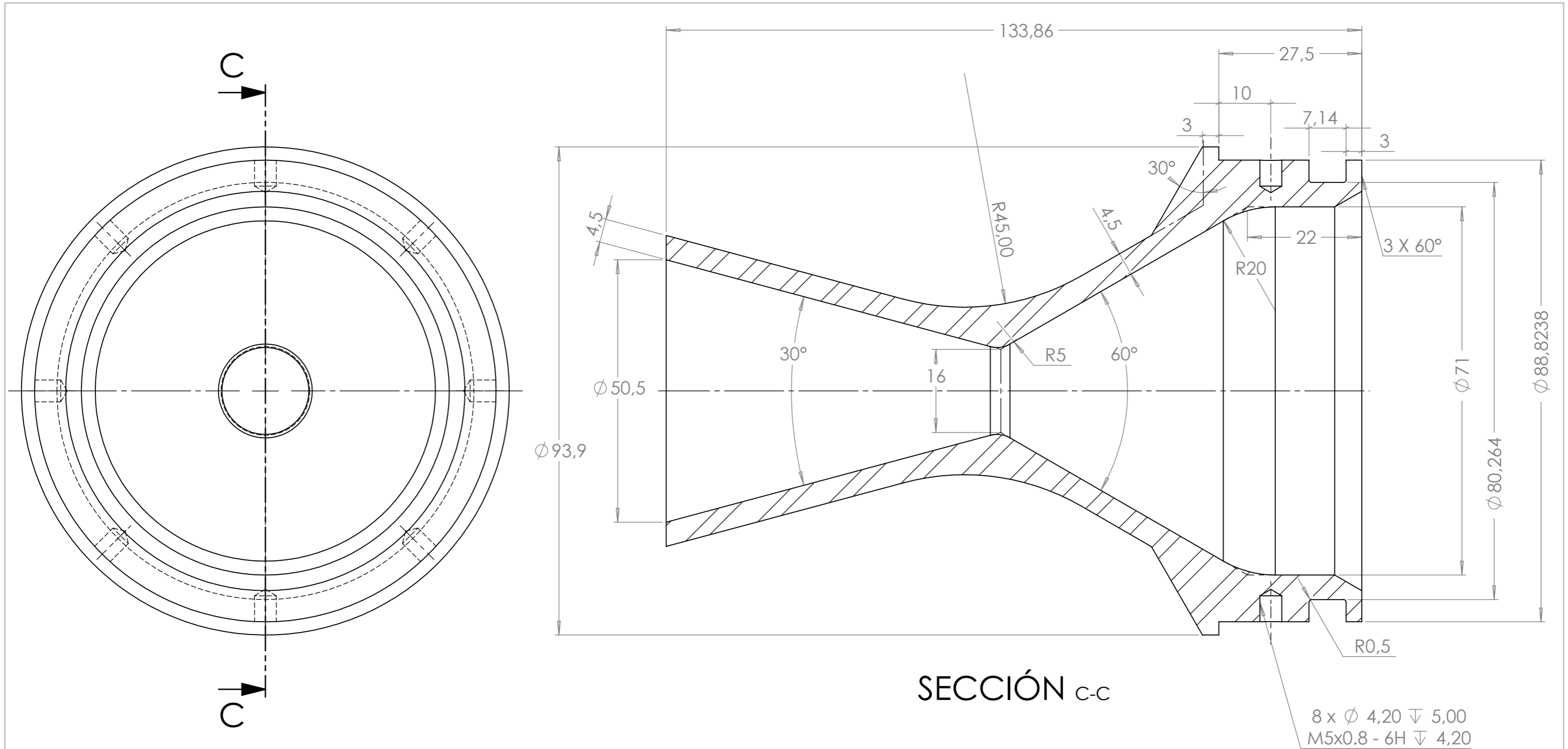

Universidad Industrial de Santander 	ESCUELA DE INGENIERIA MECANICA	
ESCALA: 3:4	CAMISA	
	DIBUJADO POR: SCUA- Orion Mision, Propulsion Team	
FORMATO A3	MATERIAL: AISI 304	HOJA 3/8
UNIDADES: mm	FECHA: 23/07/2022	PL N° 00-01-01

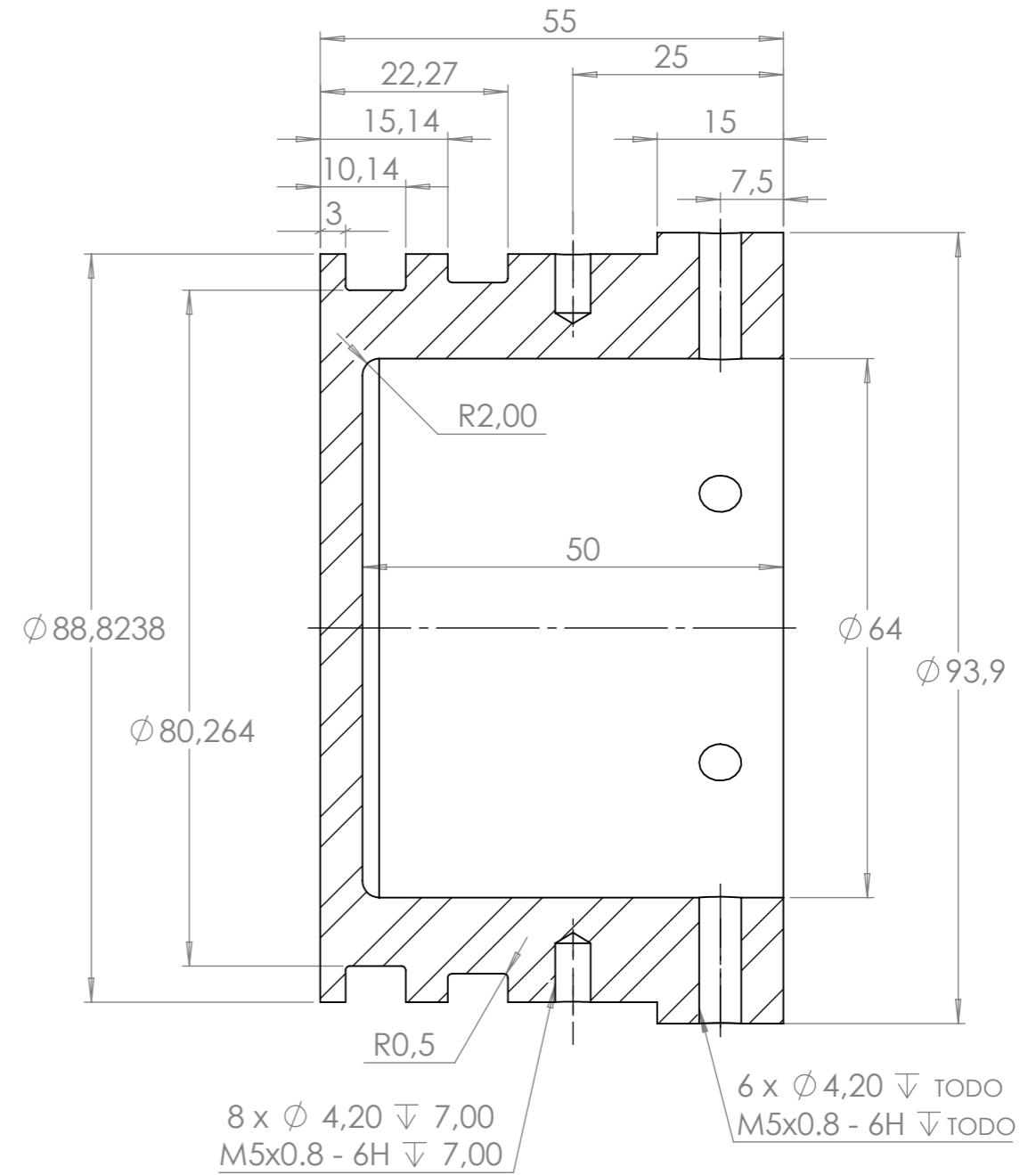
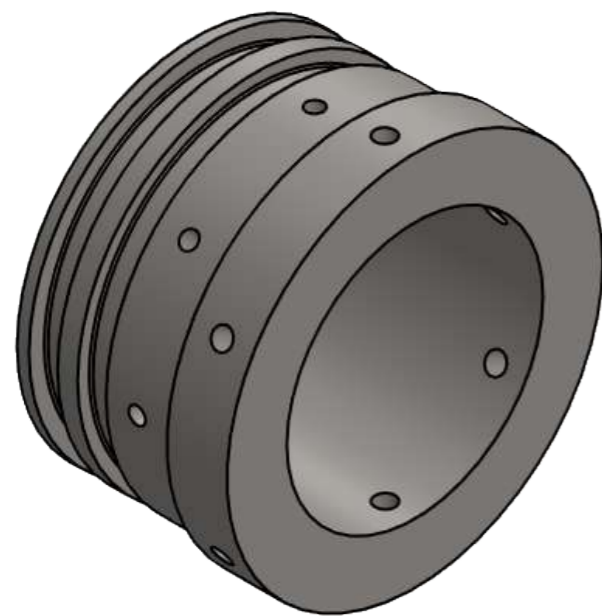
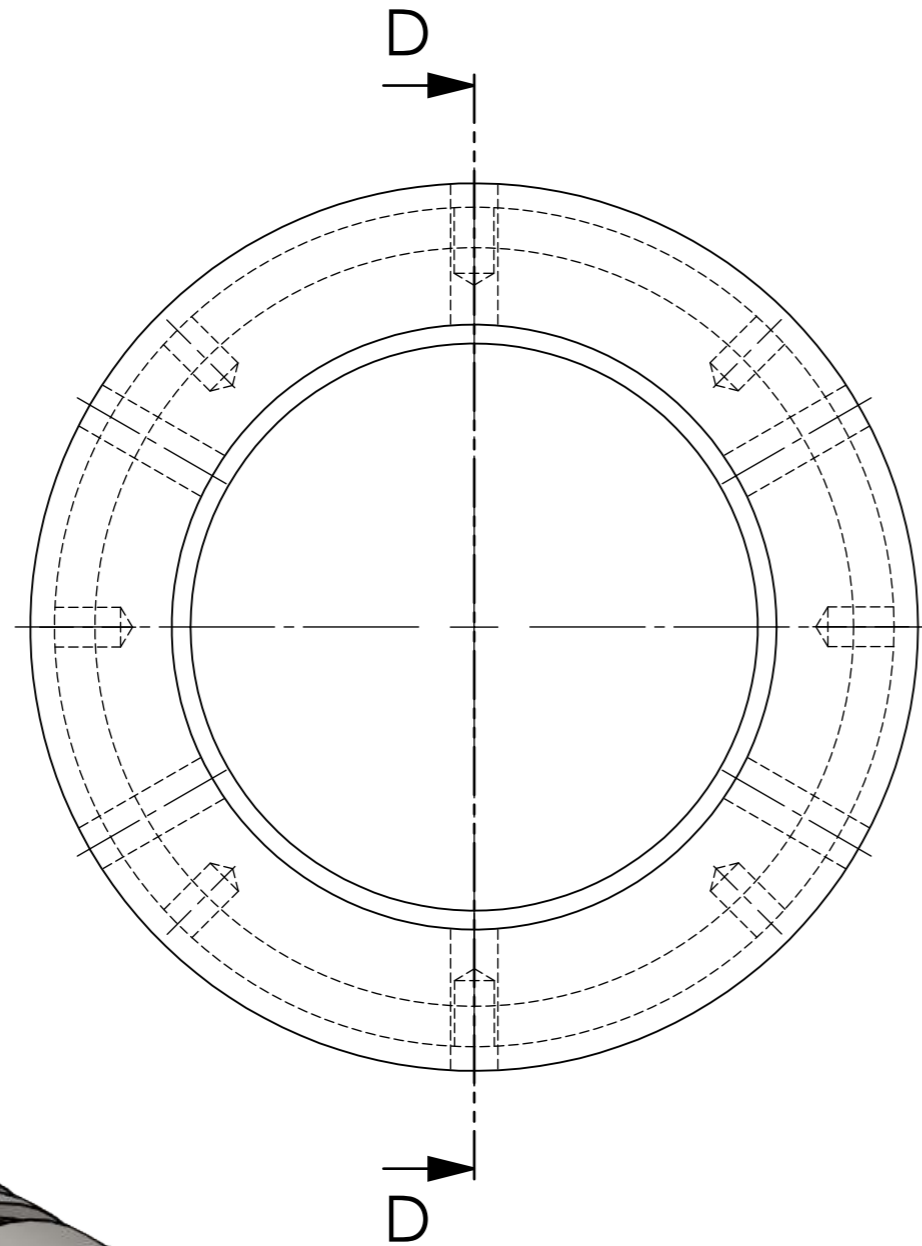

Universidad Industrial de Santander 	ESCUELA DE INGENIERIA MECANICA	
ESCALA: 4:3	TOBERA	
	DIBUJADO POR: SCUA- Orion Mision, Propulsion Team	
FORMATO A3	MATERIAL: AISI 304	HOJA 4/8
UNIDADES: mm	FECHA: 23/07/2022	PL N° 00-01-02



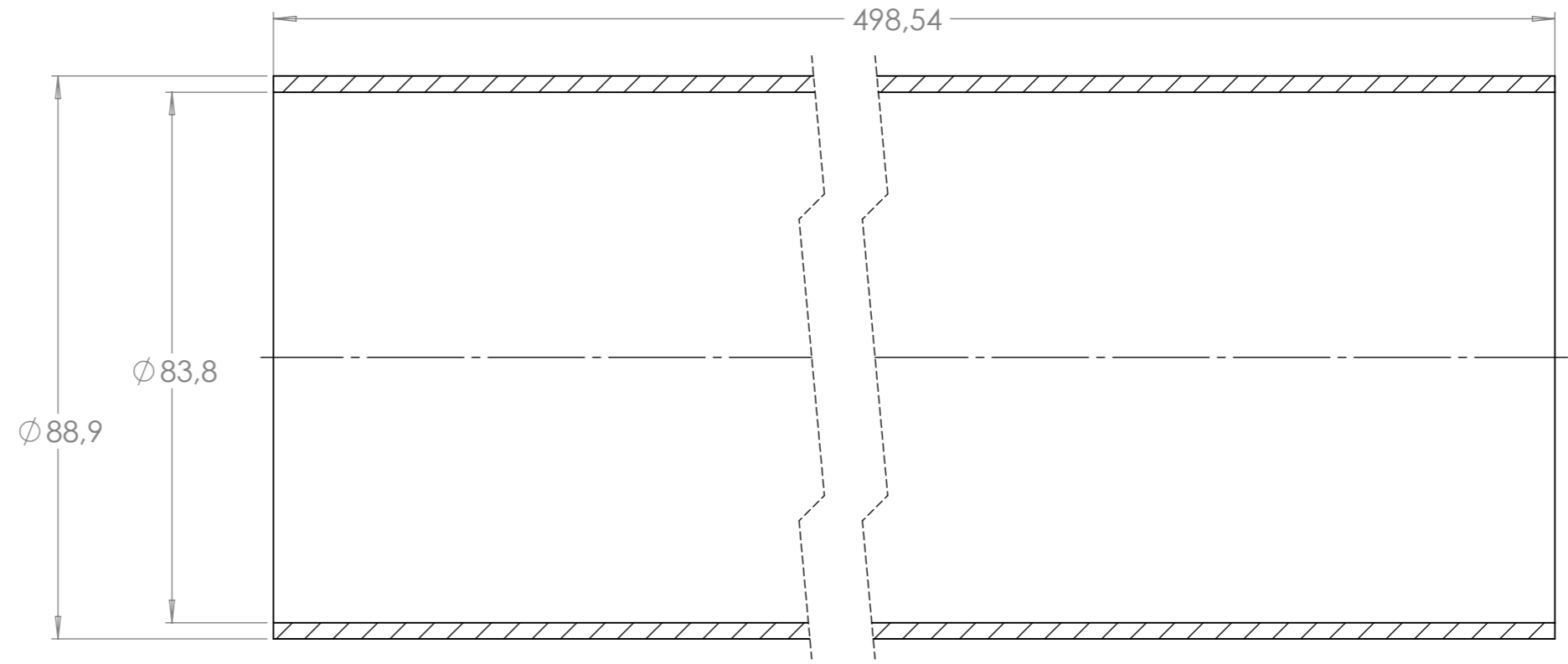
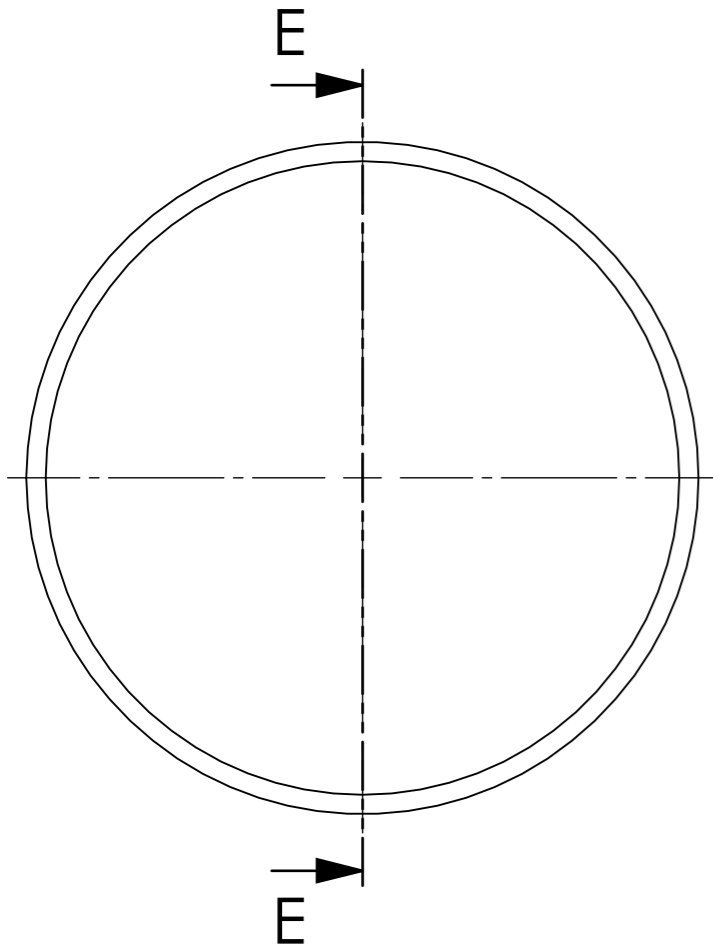

SECCIÓN D-D

Universidad Industrial de Santander 	ESCUELA DE INGENIERIA MECANICA	
ESCALA: 5:4	<i>Bulkhead</i>	
	DIBUJADO POR: SCUA- Orion Mision, Propulsion Team	
FORMATO A3	MATERIAL: AISI 304	HOJA 5/8
UNIDADES: mm	FECHA: 23/07/2022	PL N° 00-01-03

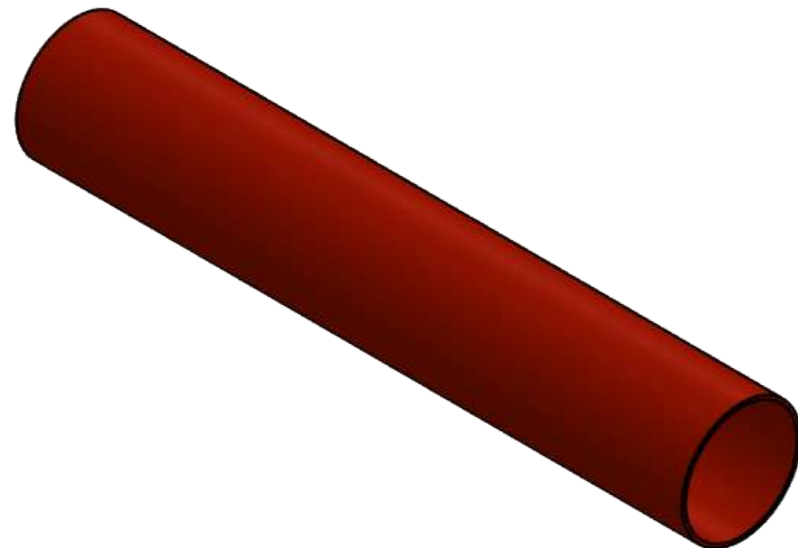

SECCIÓN E-E



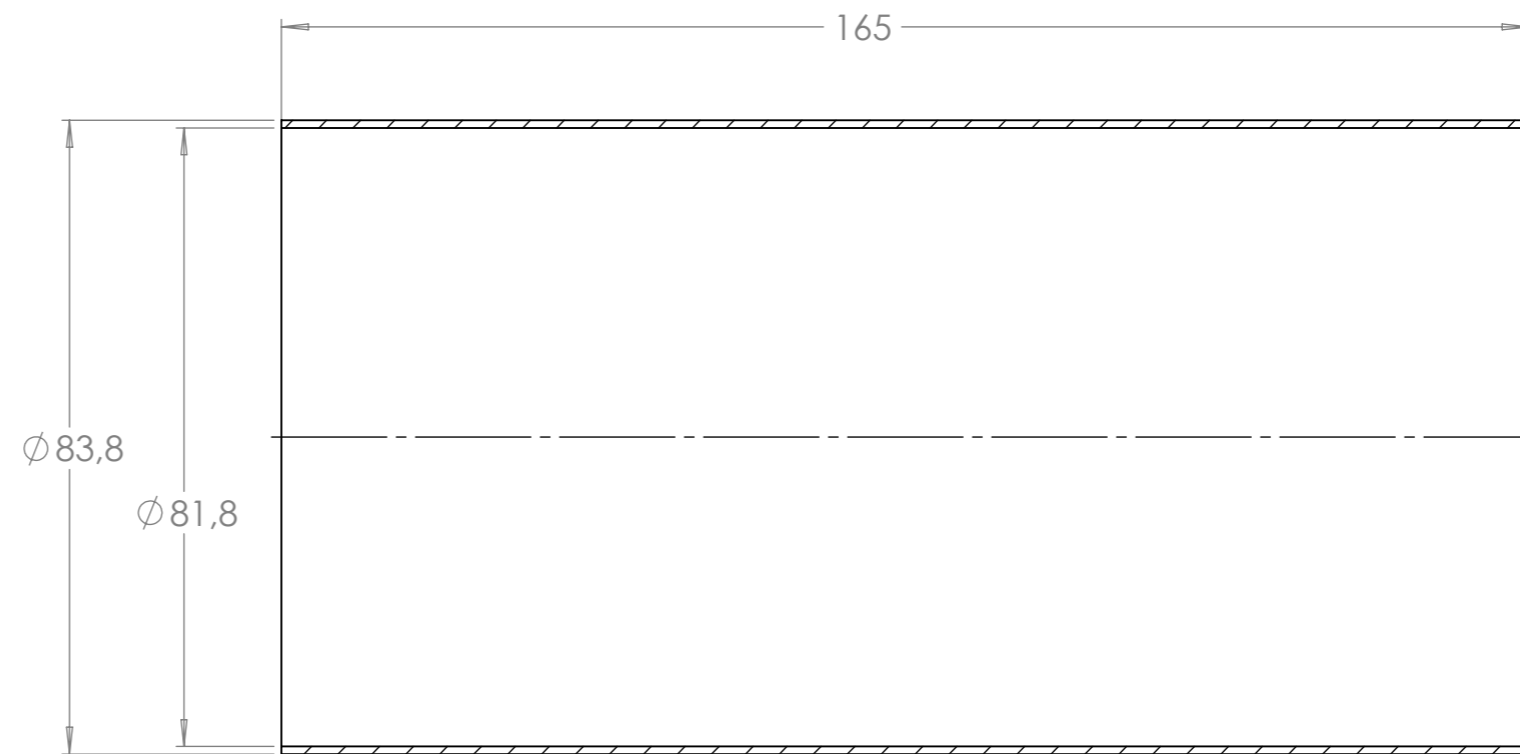
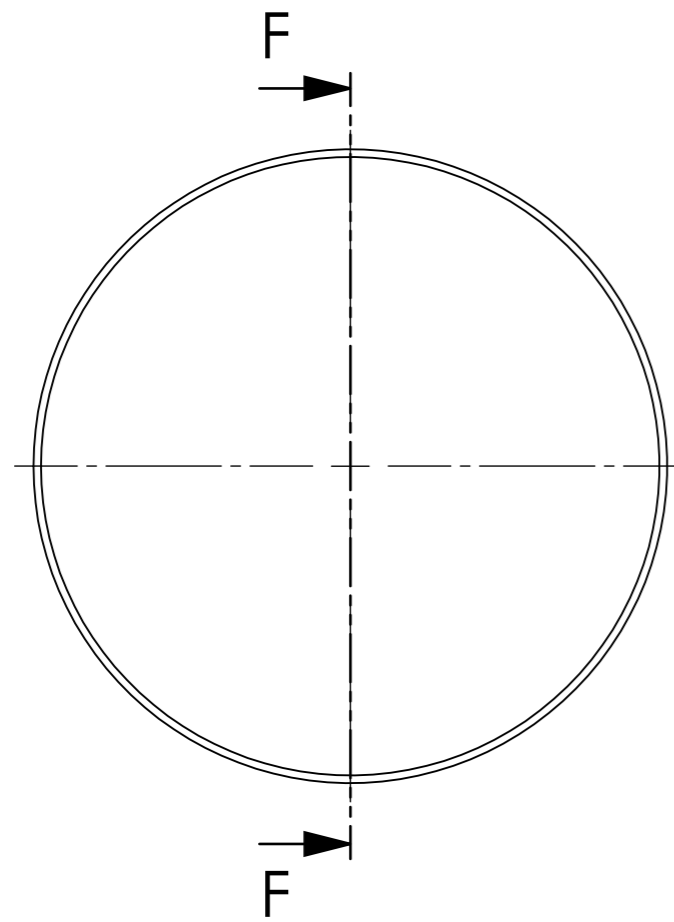

Universidad Industrial de Santander 	ESCUELA DE INGENIERIA MECANICA	
ESCALA: 1:1	LINEAR	
	DIBUJADO POR: SCUA- Orion Mision, Propulsion Team	
FORMATO A3	MATERIAL: PLA	HOJA 6/8
UNIDADES: mm	FECHA: 23/07/2022	PL N° 00-01-04

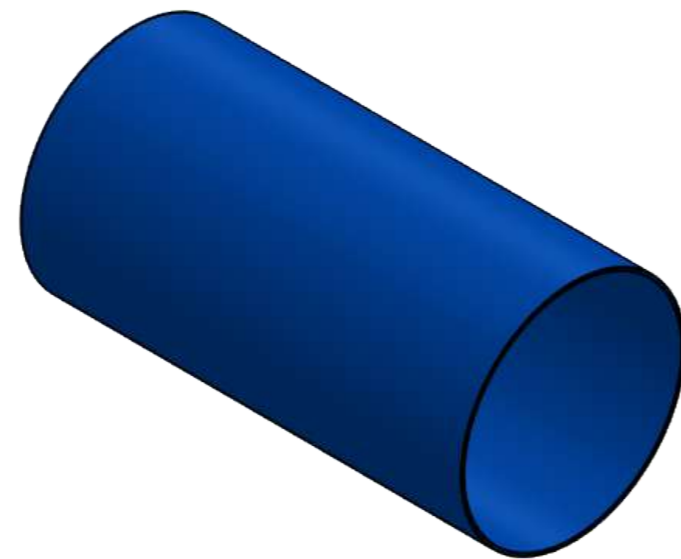

SECCIÓN F-F



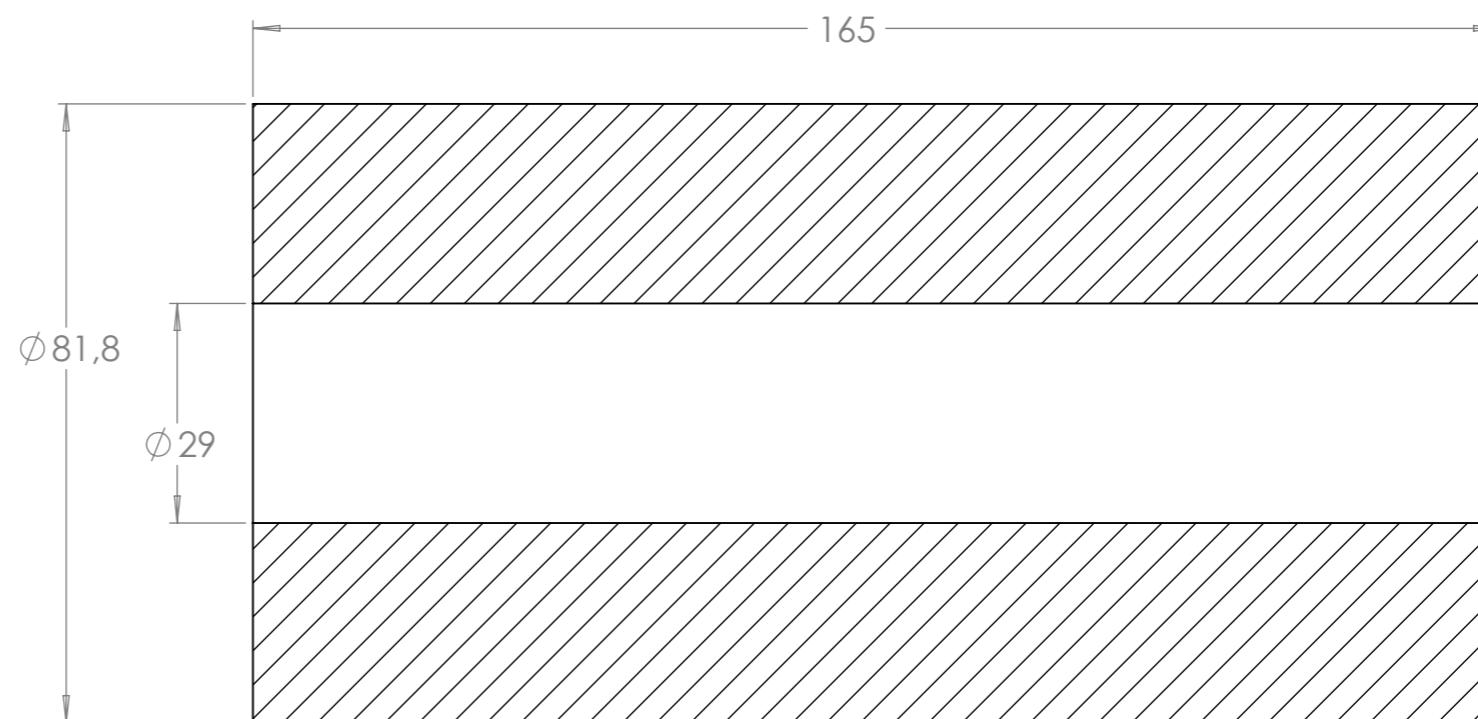
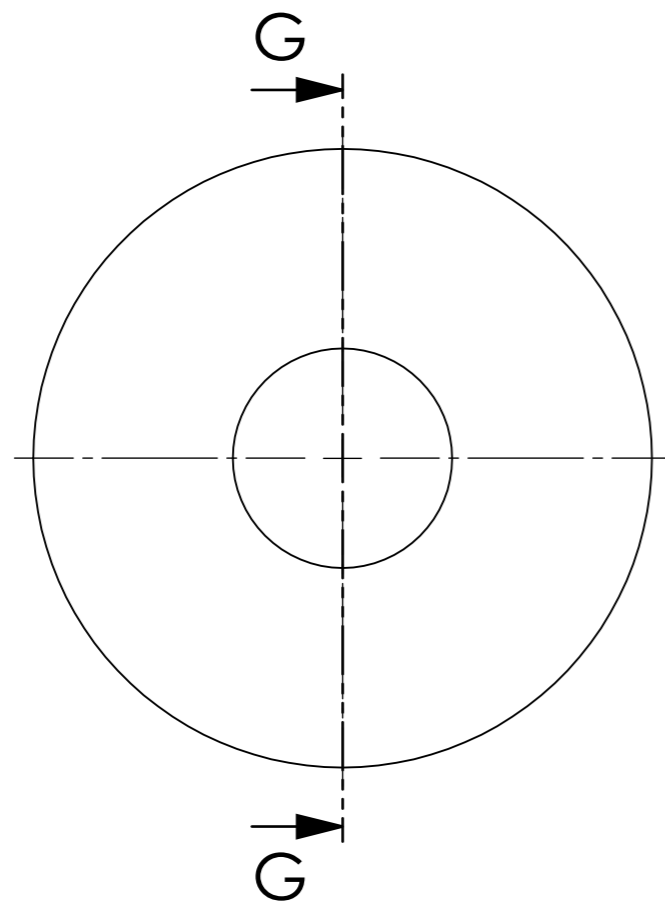

Universidad Industrial de Santander 	ESCUELA DE INGENIERIA MECANICA	
ESCALA: 1:1	AISLANTE	
	DIBUJADO POR: SCUA- Orion Mision, Propulsion Team	
FORMATO A3	MATERIAL: Cartón	HOJA 7/8
UNIDADES: mm	FECHA: 23/07/2022	PL N° 00-01-05

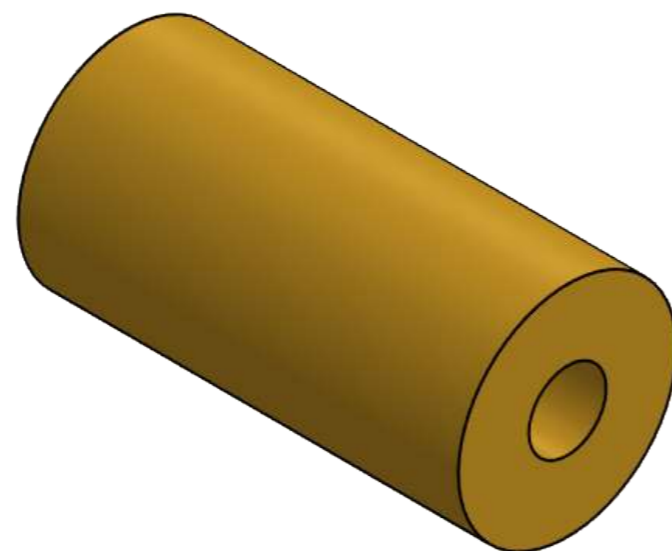

SECCIÓN G-G



Universidad Industrial de Santander 	ESCUELA DE INGENIERIA MECANICA	
ESCALA: 1:1	GRANO	
	DIBUJADO POR: SCUA- Orion Mision, Propulsion Team	
FORMATO A3	MATERIAL:	HOJA 8/8
UNIDADES: mm	FECHA: 23/07/2022	PL N° 00-01-06