

UNIVERSIDAD INDUSTRIAL DE SANTANDER

FECHA: 27/03/25

TITULO: EXTRUSORA DE ARCILLA PARA LA PRODUCCIÓN EFICIENTE DE LADRILLOS, ISOMETRICA SISTEMA TOTAL

ESCALA: 1:9

DIBUJADO POR: ERIKA TATIANA SANTOS TOLOZA

UNIDADES: mm

PRESENTADO POR: ERIKA TATIANA SANTOS TOLOZA
JHON JAIRO SEPULVEDA CAMACHO

A3



DIRECTOR: RICARDO JAIMES ROLON

HOJA 1/37

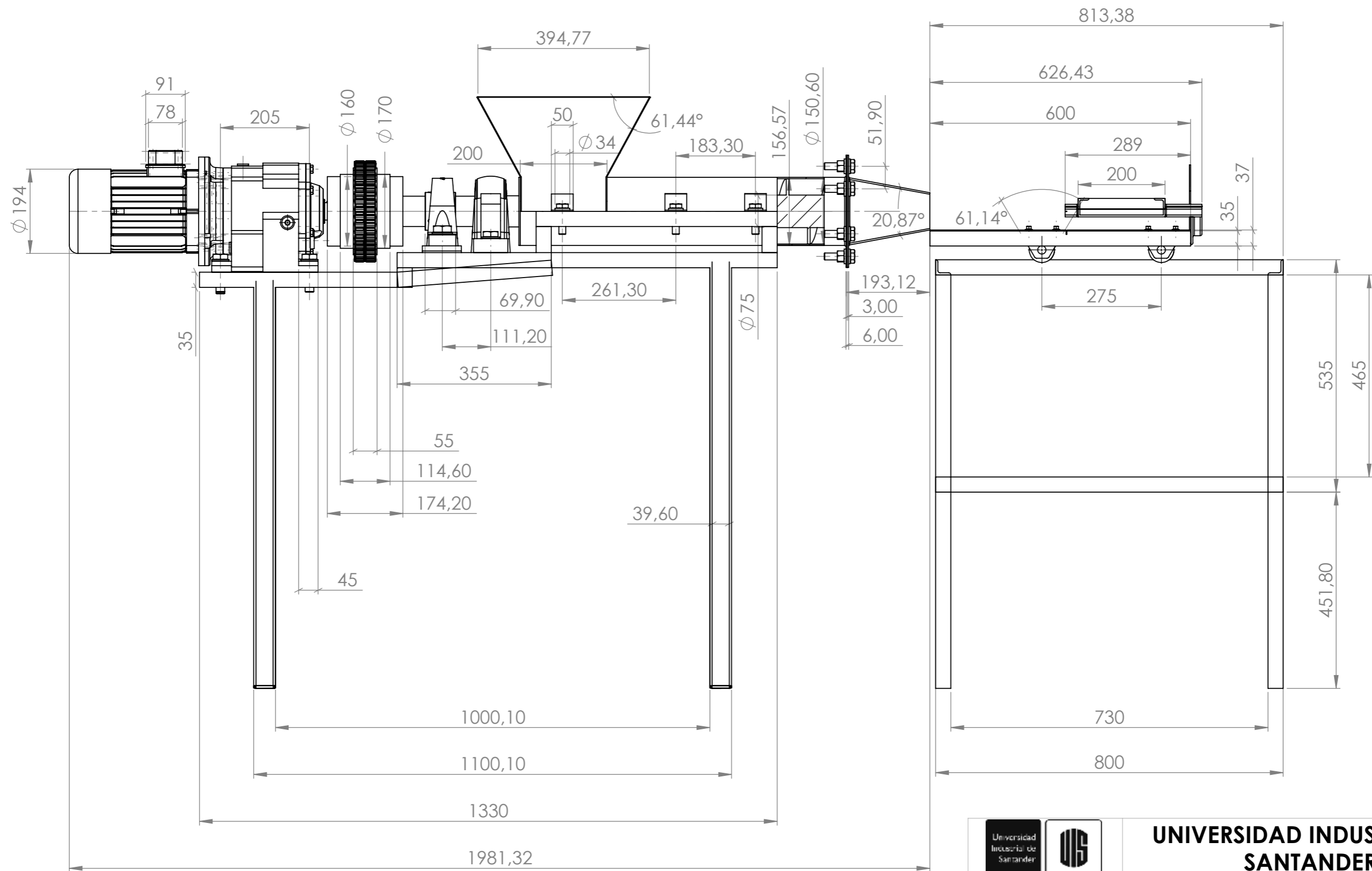

 		UNIVERSIDAD INDUSTRIAL DE SANTANDER	
FECHA: 27/03/25		TITULO: EXTRUSORA DE ARCILLA PARA LA PRODUCCIÓN EFICIENTE DE LADRILLOS, VISTA FRONTAL DEL SISTEMA	
ESCALA: 1:9		DIBUJADO POR: ERIKA TATIANA SANTOS TOLOZA	
UNIDADES: mm		PRESENTADO POR: ERIKA TATIANA SANTOS TOLOZA JHON JAIRO SEPULVEDA CAMACHO	
A3		DIRECTOR: RICARDO JAIMES ROLON	HOJA 2/37

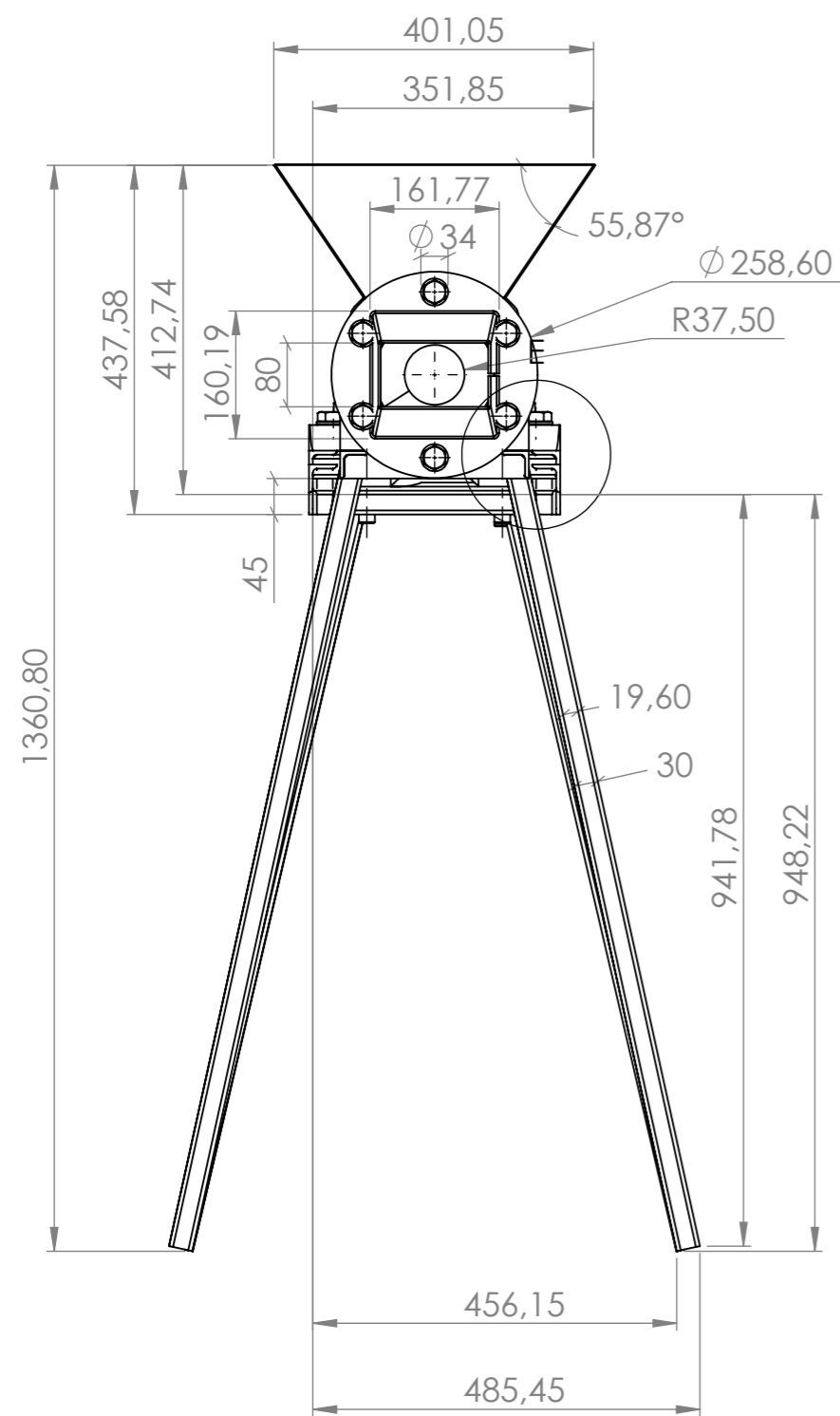

SECCIÓN B-B
ESCALA 1 : 9

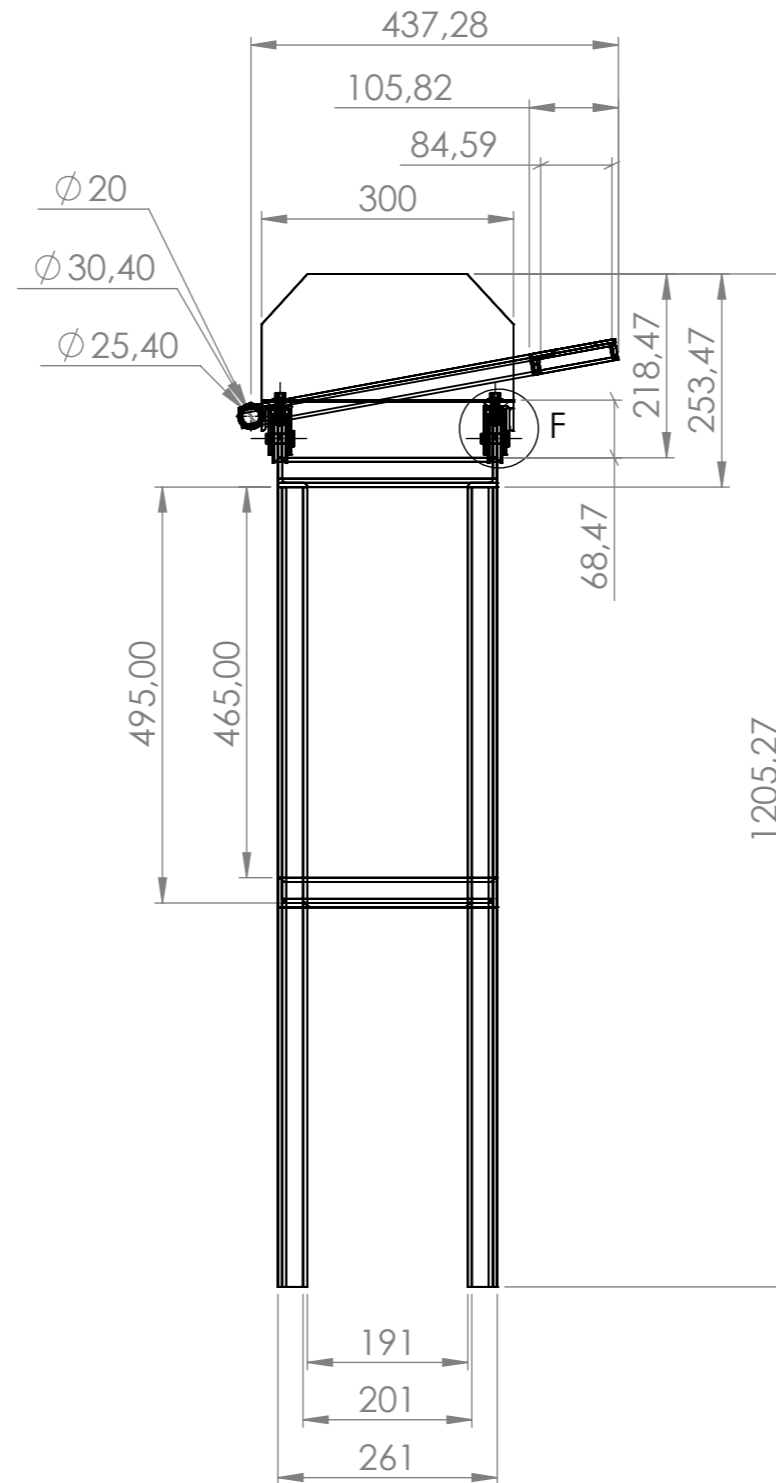

SECCIÓN C-C
ESCALA 1 : 9

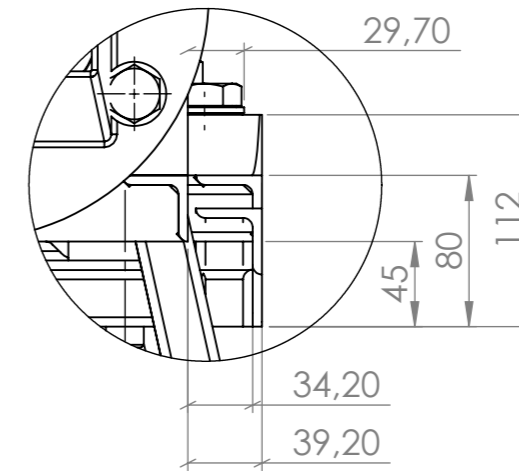

DETALLE E
ESCALA 1 : 4

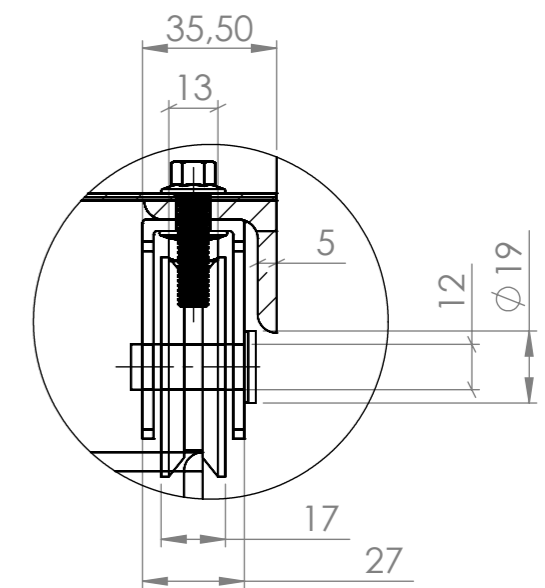

DETALLE F
ESCALA 1 : 2

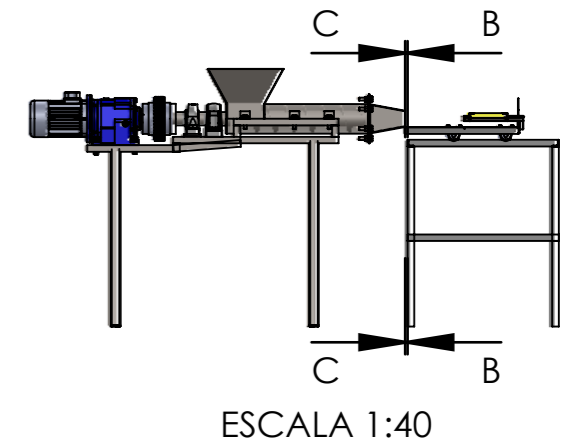

ESCALA 1:40



UNIVERSIDAD INDUSTRIAL DE SANTANDER

FECHA: 27/03/25

TITULO: EXTRUSORA DE ARCILLA PARA LA PRODUCCIÓN EFICIENTE DE LADRILLOS, VISTA LATERAL DERECHA DEL SISTEMA

ESCALA: 1:9

DIBUJADO POR: ERIKA TATIANA SANTOS TOLOZA

UNIDADES: mm

PRESENTADO POR: ERIKA TATIANA SANTOS TOLOZA
JHON JAIRO SEPULVEDA CAMACHO

A3



DIRECTOR: RICARDO JAIMES ROLON

HOJA 3/37

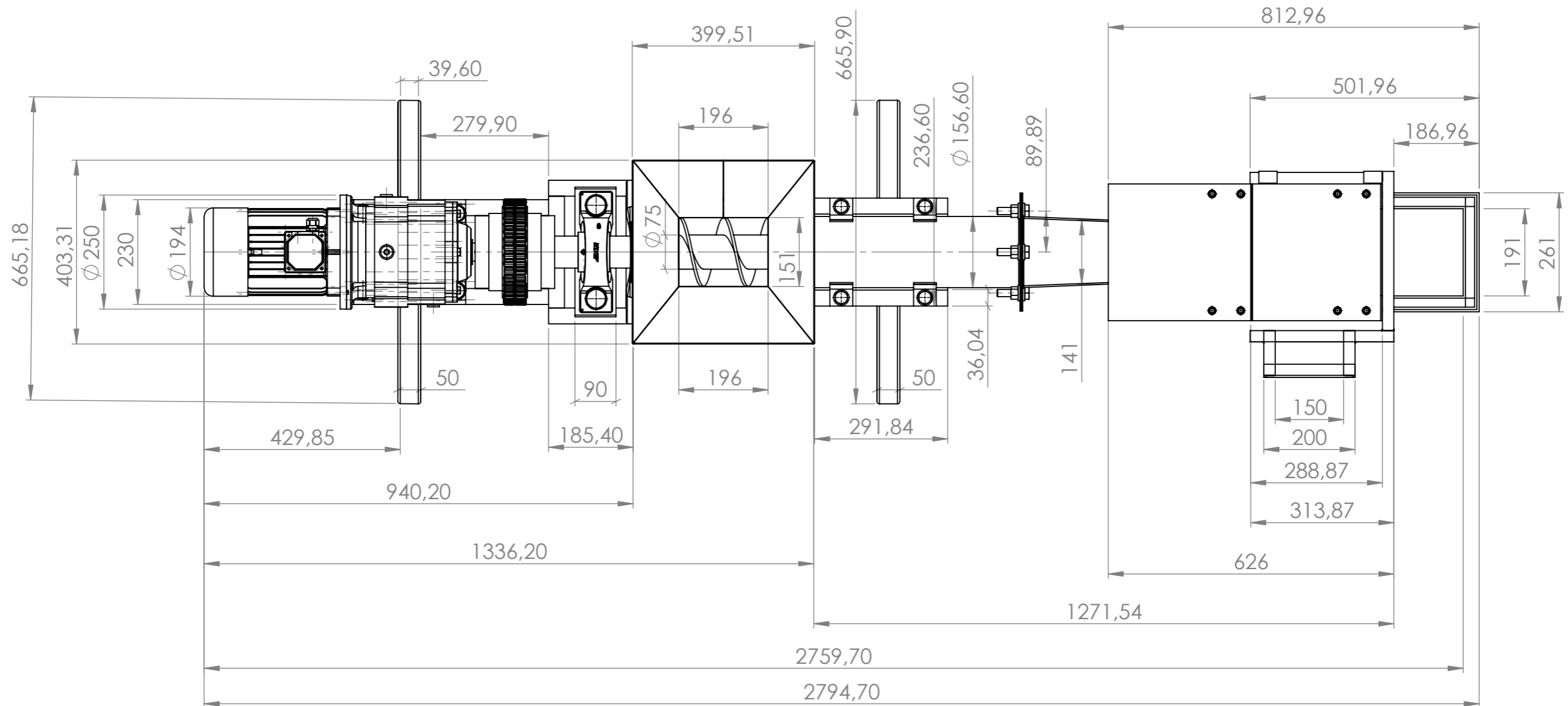

 		UNIVERSIDAD INDUSTRIAL DE SANTANDER	
FECHA: 27/03/25		TITULO: EXTRUSORA DE ARCILLA PARA LA PRODUCCIÓN EFICIENTE DE LADRILLOS, VISTA SUPERIOR DEL SISTEMA	
ESCALA: 1:10		DIBUJADO POR: ERIKA TATIANA SANTOS TOLOZA	
UNIDADES: mm		PRESENTADO POR: ERIKA TATIANA SANTOS TOLOZA JHON JAIRO SEPULVEDA CAMACHO	
A3		DIRECTOR: RICARDO JAIMES ROLON	HOJA 4/37

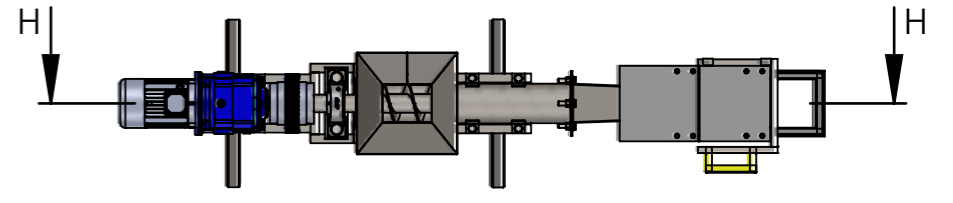

ESCALA 1:30

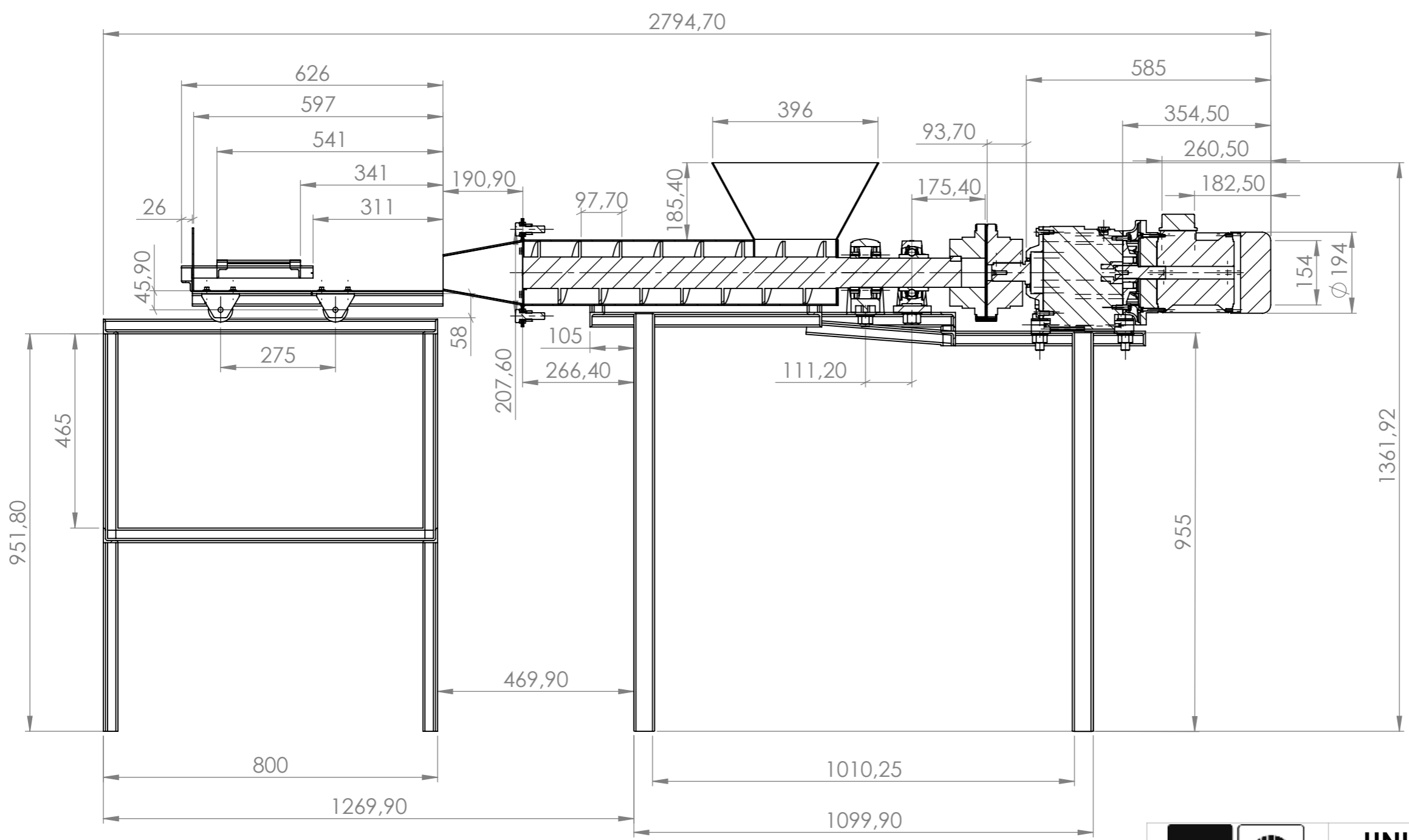

SECCIÓN H-H
ESCALA 1 : 11

 		UNIVERSIDAD INDUSTRIAL DE SANTANDER	
FECHA: 27/03/25		TITULO: EXTRUSORA DE ARCILLA PARA LA PRODUCCIÓN EFICIENTE DE LADRILLOS, VISTA DE CORTE H-H	
ESCALA: 1:11		DIBUJADO POR: ERIKA TATIANA SANTOS TOLOZA	
UNIDADES: mm		PRESENTADO POR: ERIKA TATIANA SANTOS TOLOZA JHON JAIRO SEPULVEDA CAMACHO	
A3		DIRECTOR: RICARDO JAIMES ROLON	HOJA 5/37

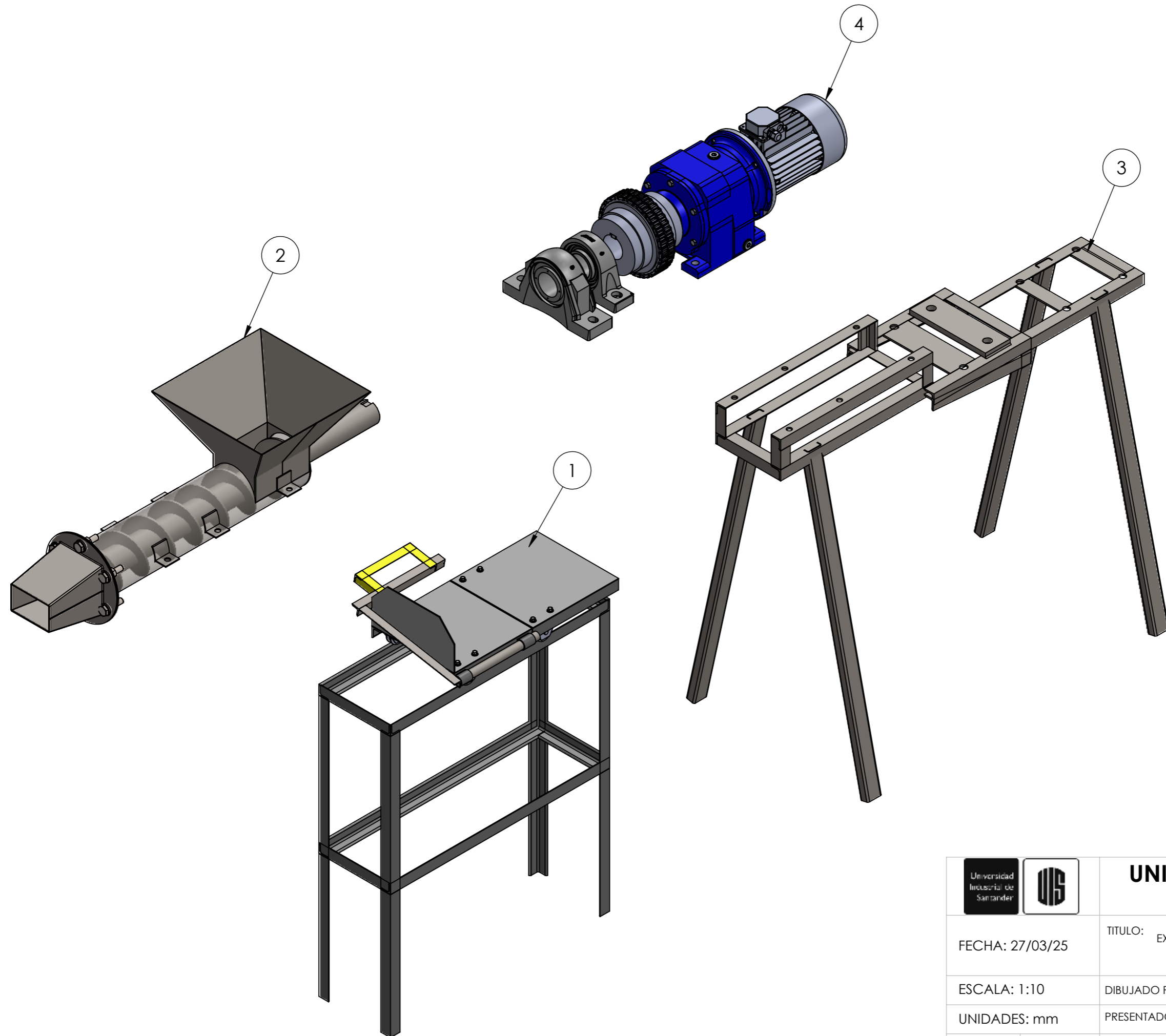

 		UNIVERSIDAD INDUSTRIAL DE SANTANDER	
FECHA: 27/03/25		TITULO: EXTRUSORA DE ARCILLA PARA LA PRODUCCIÓN EFICIENTE DE LADRILLOS, EXPLOSIONADO POR SUBSISTEMAS	
ESCALA: 1:10		DIBUJADO POR: ERIKA TATIANA SANTOS TOLOZA	
UNIDADES: mm		PRESENTADO POR: ERIKA TATIANA SANTOS TOLOZA JHON JAIRO SEPULVEDA CAMACHO	
A3		DIRECTOR: RICARDO JAIMES ROLON	HOJA 6/37



UNIVERSIDAD INDUSTRIAL DE SANTANDER

FECHA: 27/03/25

TITULO:
EXTRUSORA DE ARCILLA PARA LA PRODUCCIÓN EFICIENTE DE LADRILLOS, ISOMETRICA SUBENSAMBLAJE DE CORTE

ESCALA: 1:6

DIBUJADO POR: ERIKA TATIANA SANTOS TOLOZA

UNIDADES: mm

PRESENTADO POR: ERIKA TATIANA SANTOS TOLOZA
JHON JAIRO SEPULVEDA CAMACHO

A3



DIRECTOR: RICARDO JAIMES ROLON

HOJA 7/37

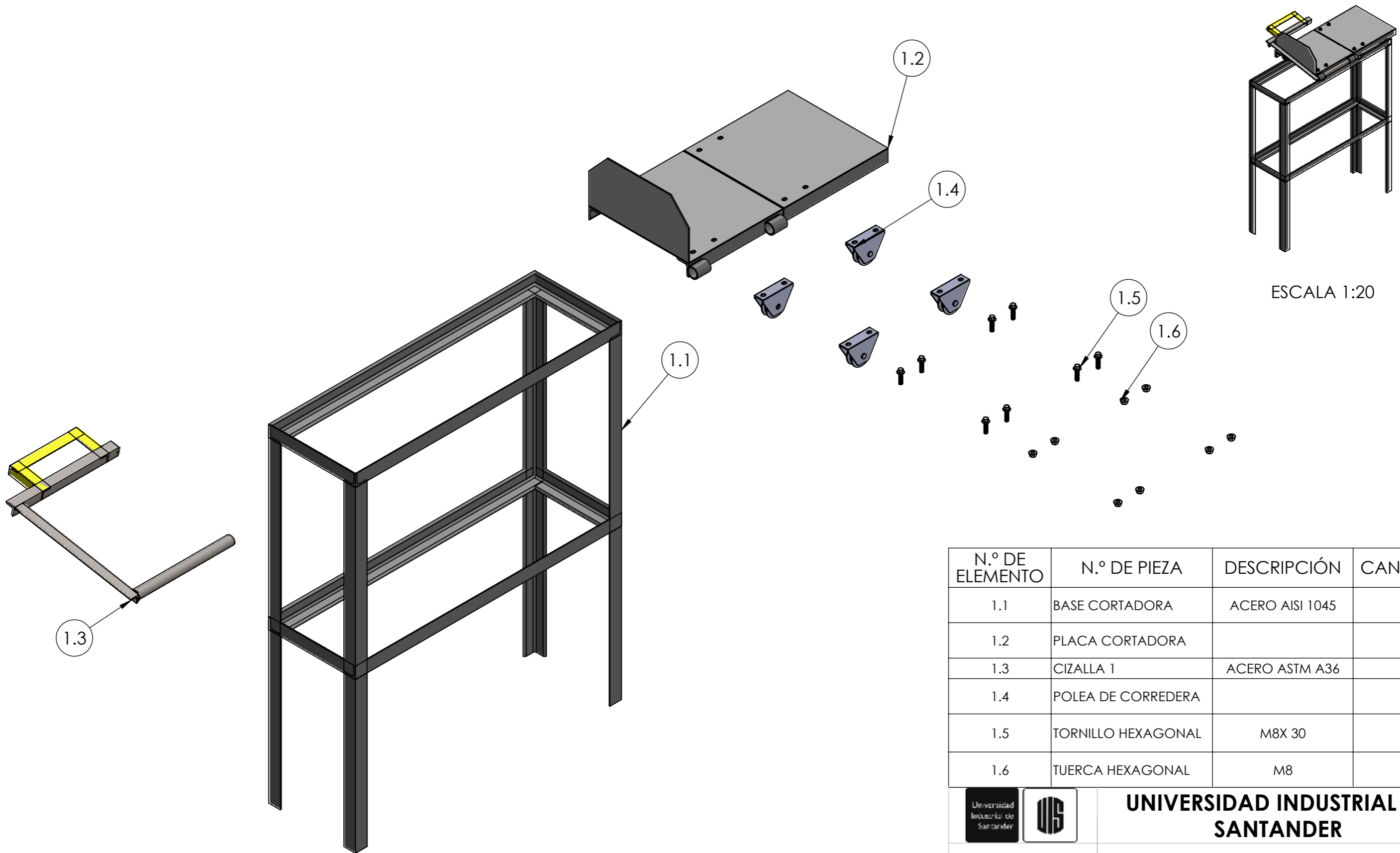

N.º DE ELEMENTO	N.º DE PIEZA	DESCRIPCIÓN	CANTIDAD
1.1	BASE CORTADORA	ACERO AISI 1045	1
1.2	PLACA CORTADORA		1
1.3	CIZALLA 1	ACERO ASTM A36	1
1.4	POLEA DE CORREDERA		4
1.5	TORNILLO HEXAGONAL	M8X 30	8
1.6	TUERCA HEXAGONAL	M8	8

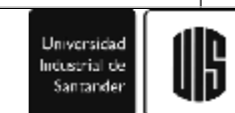

UNIVERSIDAD INDUSTRIAL DE SANTANDER

FECHA: 27/03/25

TITULO: EXTRUSORA DE ARCILLA PARA LA PRODUCCIÓN EFICIENTE DE LADRILLOS, EXPLOSIONADO SUBSISTEMA DE CORTE

ESCALA: 1:8

DIBUJADO POR: ERIKA TATIANA SANTOS TOLOZA

UNIDADES: mm

PRESENTADO POR: ERIKA TATIANA SANTOS TOLOZA
JHON JAIRO SEPULVEDA CAMACHO

A3



DIRECTOR: RICARDO JAIMES ROLON

HOJA 8/37

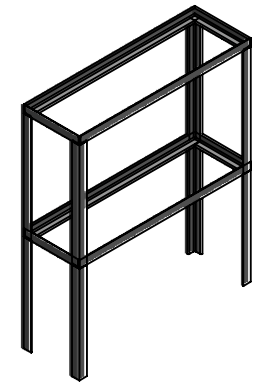
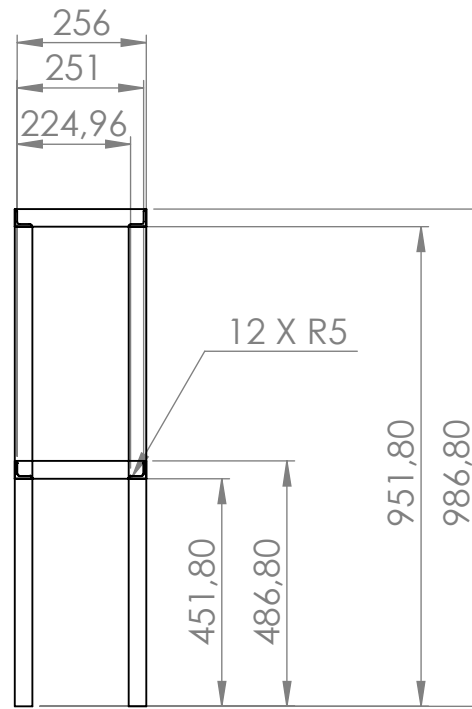
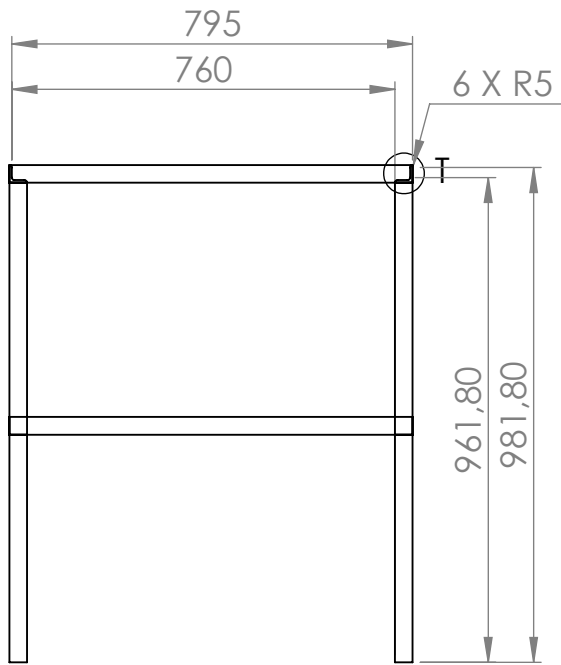

ESCALA 1:25

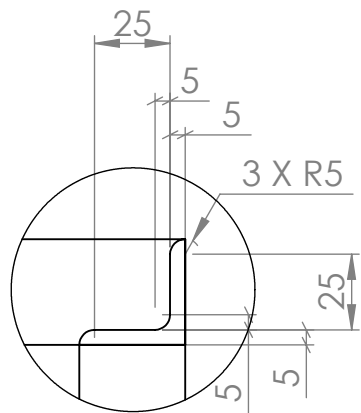

DETALLE T
ESCALA 2 : 5

 		UNIVERSIDAD INDUSTRIAL DE SANTANDER	
FECHA: 27/03/25		TITULO: EXTRUSORA DE ARCILLA PARA LA PRODUCCIÓN EFICIENTE DE LADRILLOS, PLANO DE PIEZA CÓDIGO DE PIEZA: 1.1 BASE CORTADORA	
ESCALA: 1:15		DIBUJADO POR: ERIKA TATIANA SANTOS TOLOZA	
UNIDADES: mm		PRESENTADO POR: ERIKA TATIANA SANTOS TOLOZA JHON JAIRO SEPULVEDA CAMACHO	
A4		DIRECTOR: RICARDO JAIMES ROLON	HOJA 9/37

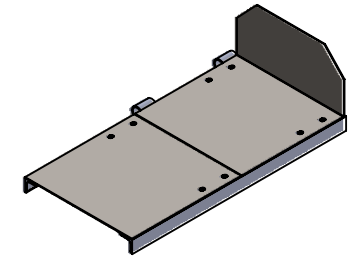
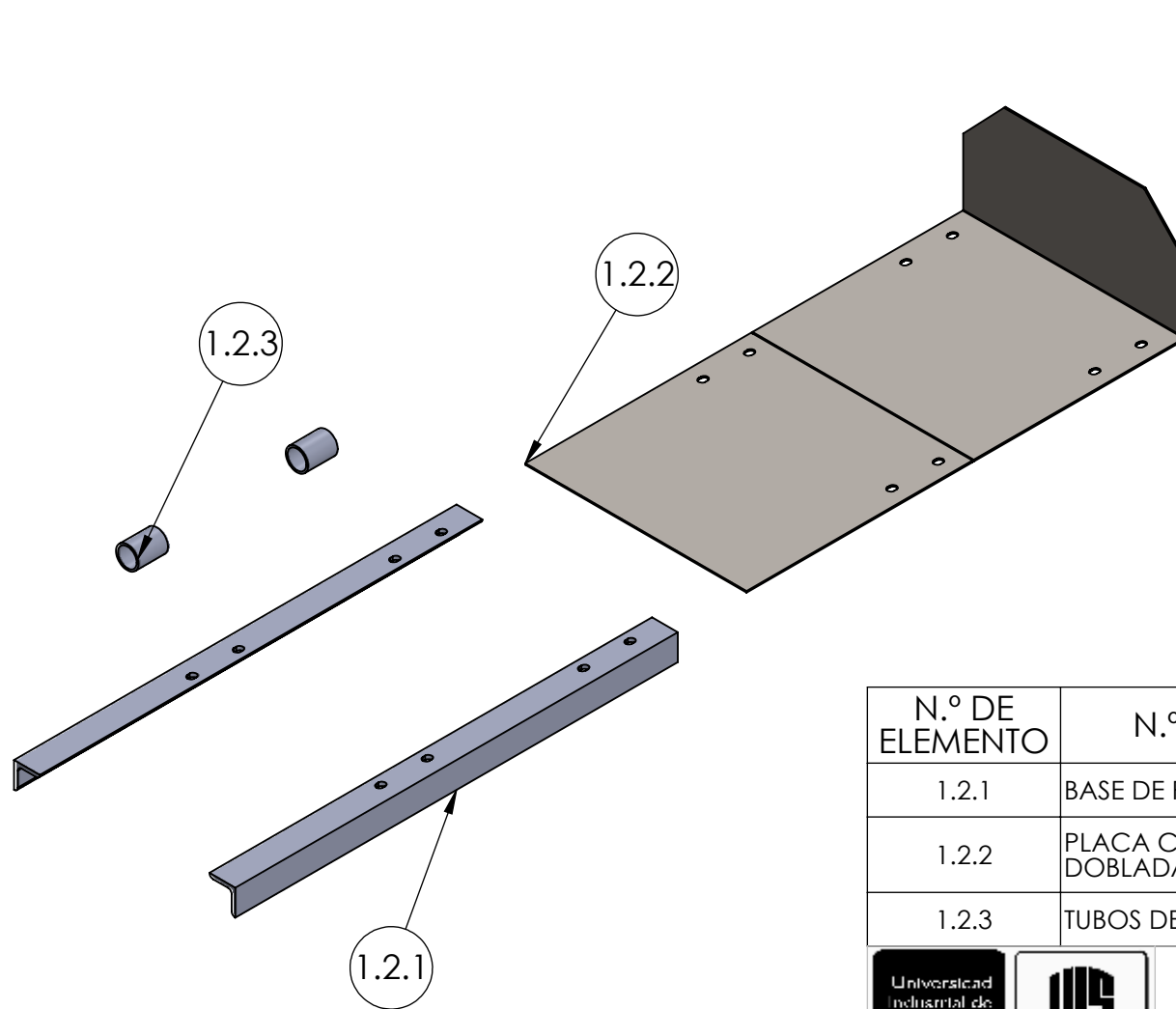

ESCALA 1:15

N.º DE ELEMENTO	N.º DE PIEZA	DESCRIPCIÓN	CANTIDAD
1.2.1	BASE DE PLACA		1
1.2.2	PLACA CORTADORA DOBLADA	ACERO AISI1045	1
1.2.3	TUBOS DE EJE		1



UNIVERSIDAD INDUSTRIAL DE SANTANDER

FECHA: 27/03/25

TÍTULO: EXTRUSORA DE ARCILLA PARA LA PRODUCCIÓN EFICIENTE DE LADRILLOS, PLANO DE PIEZA
CÓDIGO DE PIEZA: 1.2 PLACA CORTADORA

ESCALA: 1:7

DIBUJADO POR: ERIKA TATIANA SANTOS TOLOZA

UNIDADES: mm

PRESENTADO POR: ERIKA TATIANA SANTOS TOLOZA
JHON JAIRO SEPULVEDA CAMACHO

A4

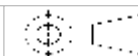

DIRECTOR: RICARDO JAIMES ROLON

HOJA 10/37

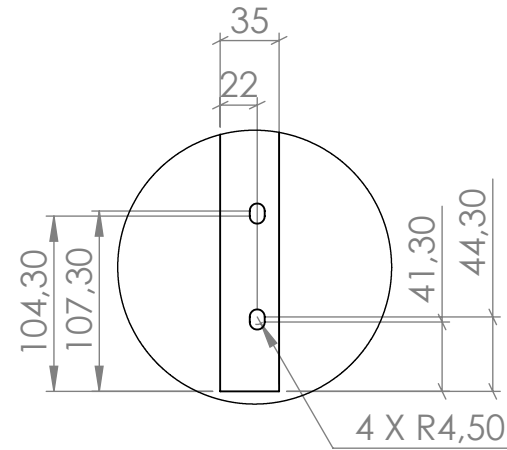
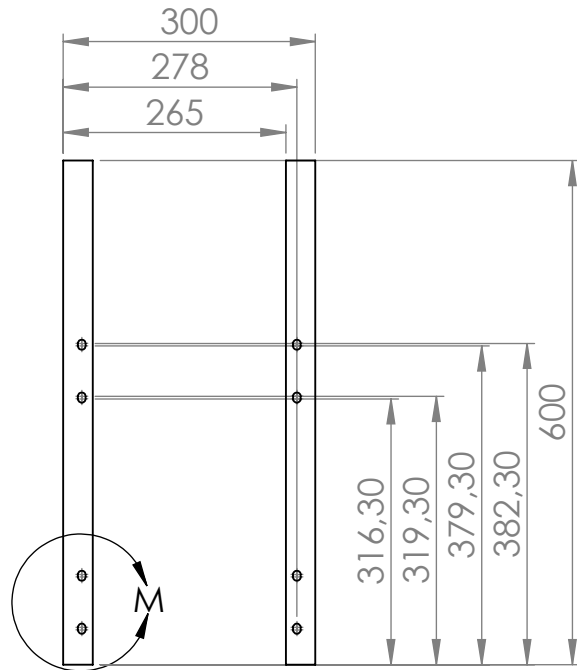

DETALLE M
ESCALA 2 : 9

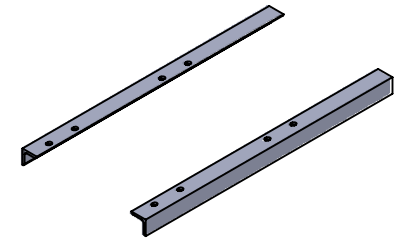

ESCALA 1:13

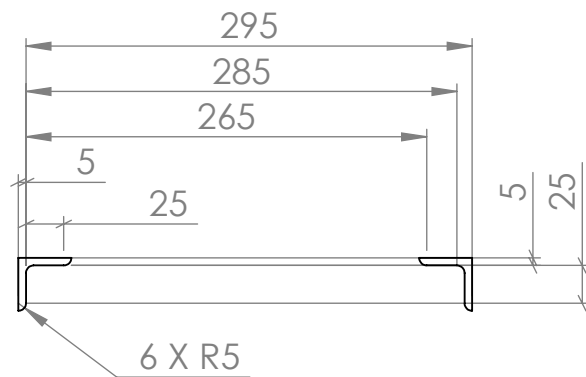

 		UNIVERSIDAD INDUSTRIAL DE SANTANDER	
FECHA: 27/03/25		TITULO: EXTRUSORA DE ARCILLA PARA LA PRODUCCIÓN EFICIENTE DE LADRILLOS, PLANO DE PIEZA CÓDIGO DE PIEZA: 1.2.1 BASE DE PLACA	
ESCALA: 1:9		DIBUJADO POR: ERIKA TATIANA SANTOS TOLOZA	
UNIDADES: mm		PRESENTADO POR: ERIKA TATIANA SANTOS TOLOZA JHON JAIRO SEPULVEDA CAMACHO	
A4		DIRECTOR: RICARDO JAIMES ROLON	HOJA 11/37

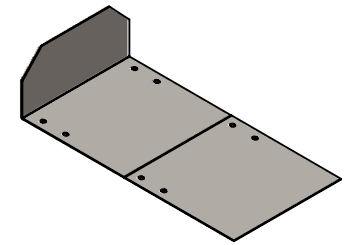
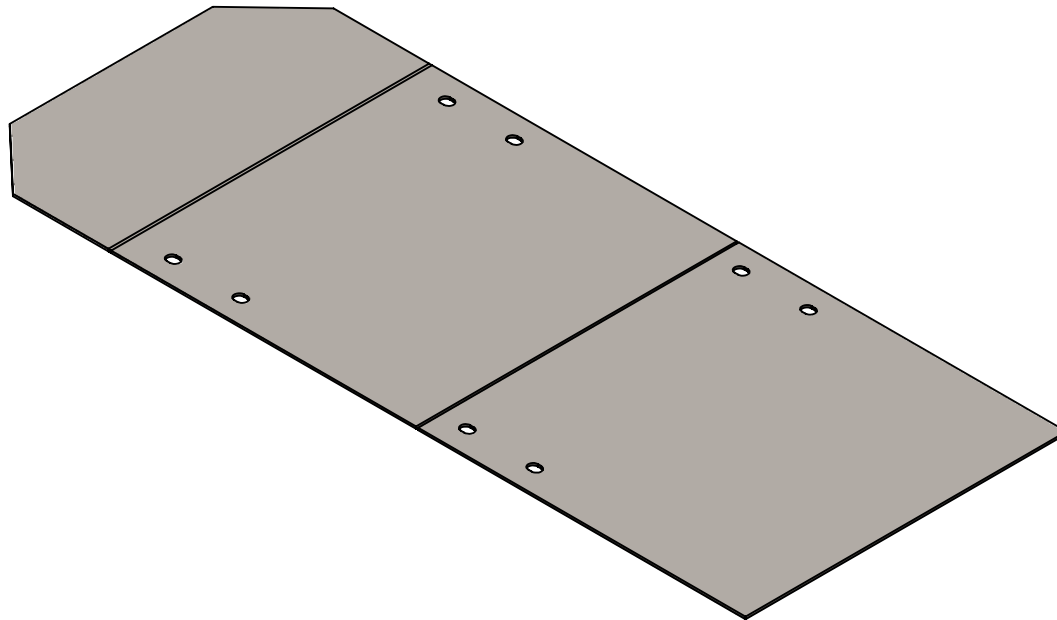

ESCALA 1:15

 		UNIVERSIDAD INDUSTRIAL DE SANTANDER	
FECHA: 27/03/25		TITULO: EXTRUSORA DE ARCILLA PARA LA PRODUCCIÓN EFICIENTE DE LADRILLOS, PLANO DE PIEZA CÓDIGO DE PIEZA: 1.2.2 PLACA CORTADORA DESDOBLADA	
ESCALA: 1:5		DIBUJADO POR: ERIKA TATIANA SANTOS TOLOZA	
UNIDADES: mm		PRESENTADO POR: ERIKA TATIANA SANTOS TOLOZA JHON JAIRO SEPULVEDA CAMACHO	
A4		DIRECTOR: RICARDO JAIMES ROLON	HOJA 12/37

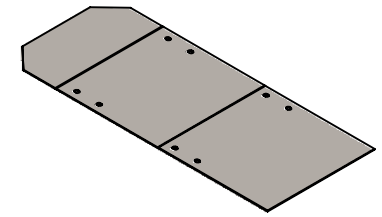
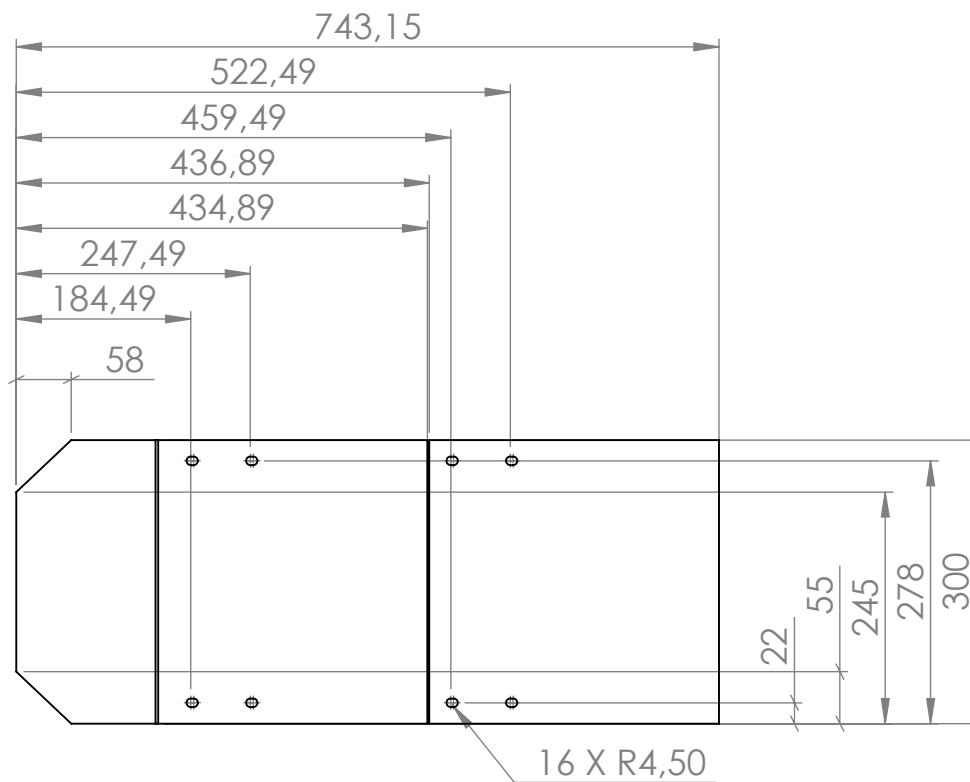

ESCALA 1:15

 		UNIVERSIDAD INDUSTRIAL DE SANTANDER	
FECHA: 27/03/25		TITULO: EXTRUSORA DE ARCILLA PARA LA PRODUCCIÓN EFICIENTE DE LADRILLOS, PLANO DE PIEZA CÓDIGO DE PIEZA: 1.2.2 PLACA CORTADORA DESDOBLADA	
ESCALA: 1:8		DIBUJADO POR: ERIKA TATIANA SANTOS TOLOZA	
UNIDADES: mm		PRESENTADO POR: ERIKA TATIANA SANTOS TOLOZA JHON JAIRO SEPULVEDA CAMACHO	
A4		DIRECTOR: RICARDO JAIMES ROLON	HOJA 13/37

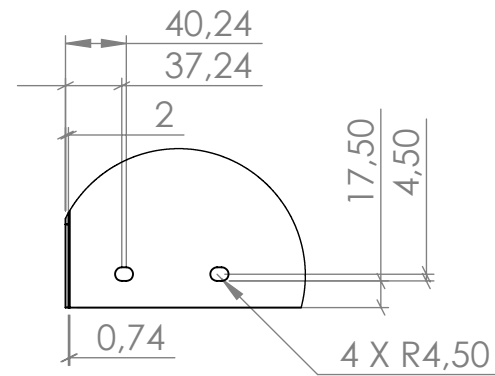
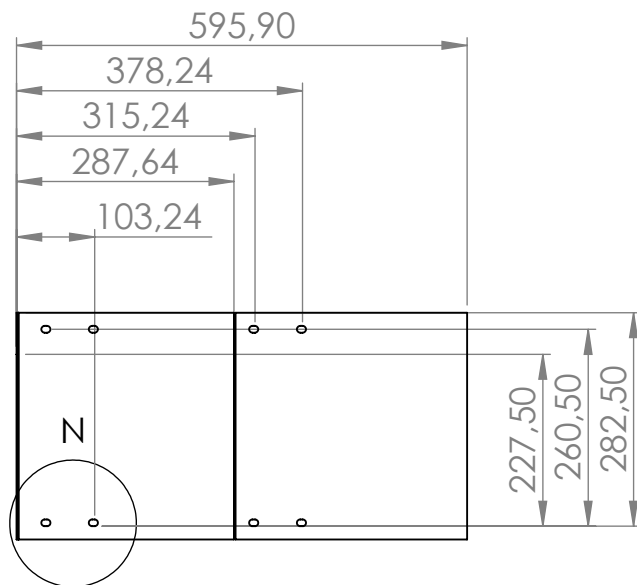

DETALLE N
ESCALA 1 : 5

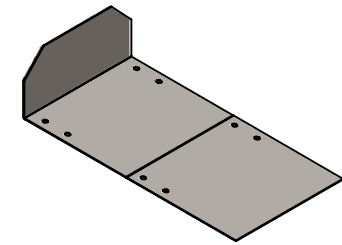

ESCALA 1:15

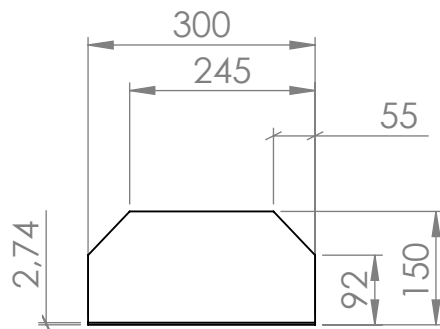

 		UNIVERSIDAD INDUSTRIAL DE SANTANDER	
FECHA: 27/03/25		TITULO: EXTRUSORA DE ARCILLA PARA LA PRODUCCIÓN EFICIENTE DE LADRILLOS, PLANO DE PIEZA CÓDIGO DE PIEZA: 1.2.2 PLACA CORTADORA DOBLADA	
ESCALA: 1:10		DIBUJADO POR: ERIKA TATIANA SANTOS TOLOZA	
UNIDADES: mm		PRESENTADO POR: ERIKA TATIANA SANTOS TOLOZA JHON JAIRO SEPULVEDA CAMACHO	
A4		DIRECTOR: RICARDO JAIMES ROLON	HOJA 14/37

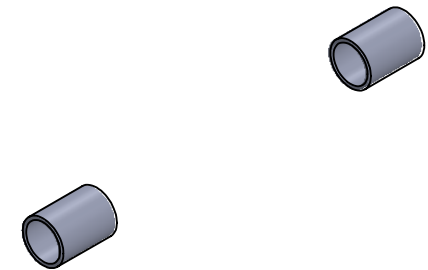
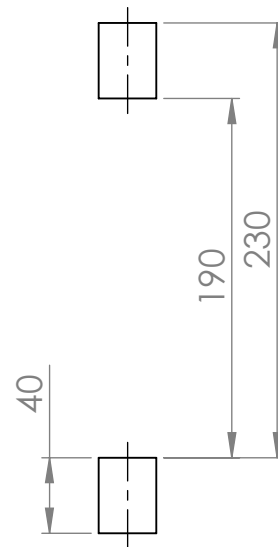
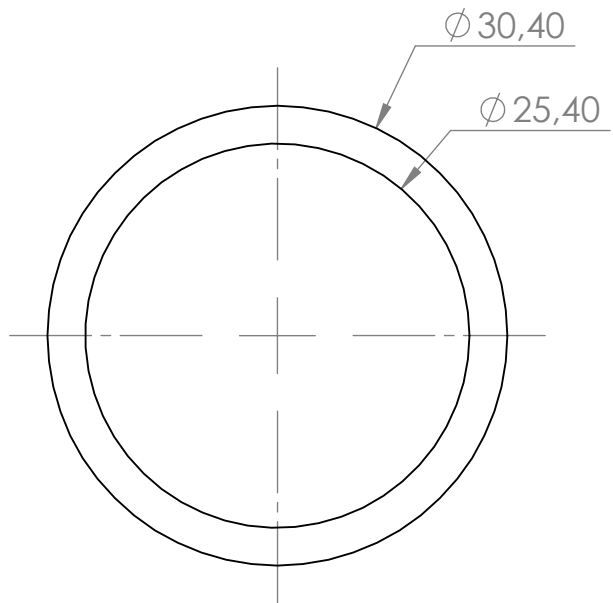

ESCALA 1:4

 		UNIVERSIDAD INDUSTRIAL DE SANTANDER	
FECHA: 27/03/25		TITULO: EXTRUSORA DE ARCILLA PARA LA PRODUCCIÓN EFICIENTE DE LADRILLOS, PLANO DE PIEZA CÓDIGO DE PIEZA: 1.2.3 TUBOS DE EJE	
ESCALA: 2:1		DIBUJADO POR: ERIKA TATIANA SANTOS TOLOZA	
UNIDADES: mm		PRESENTADO POR: ERIKA TATIANA SANTOS TOLOZA JHON JAIRO SEPULVEDA CAMACHO	
A4		DIRECTOR: RICARDO JAIMES ROLON	HOJA 15/37

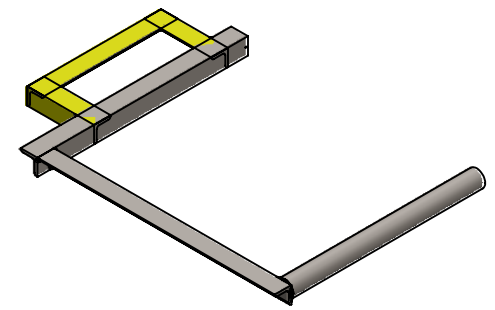
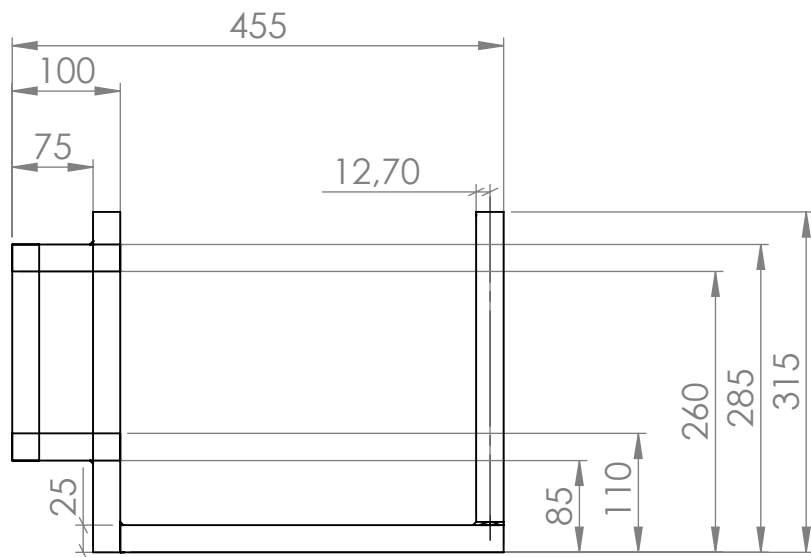

ESCALA 1:8

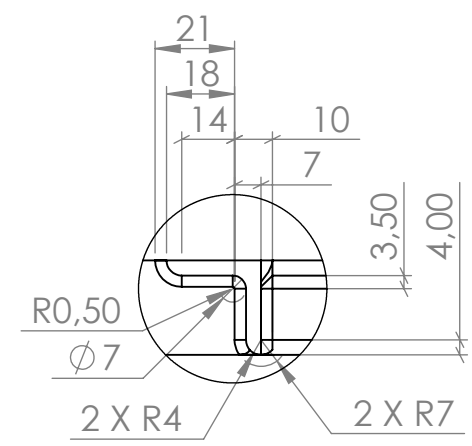

DETALLE U
ESCALA 1 : 2

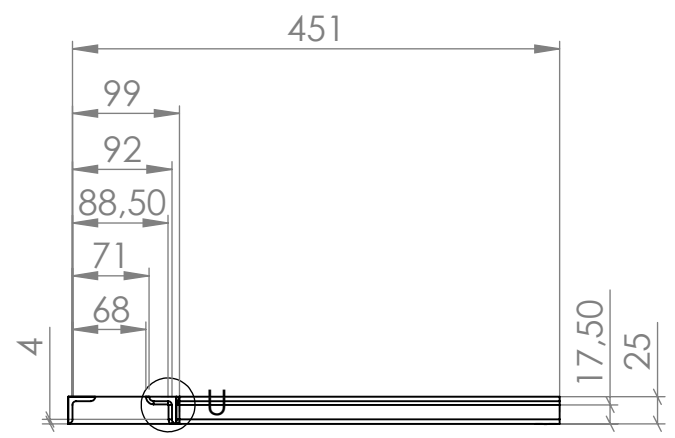

 		UNIVERSIDAD INDUSTRIAL DE SANTANDER	
FECHA: 27/03/25		TITULO: EXTRUSORA DE ARCILLA PARA LA PRODUCCIÓN EFICIENTE DE LADRILLOS, PLANO DE PIEZA CÓDIGO DE PIEZA: 1.3 CIZALLA 1	
ESCALA: 1:7		DIBUJADO POR: ERIKA TATIANA SANTOS TOLOZA	
UNIDADES: mm		PRESENTADO POR: ERIKA TATIANA SANTOS TOLOZA JHON JAIRO SEPULVEDA CAMACHO	
A4		DIRECTOR: RICARDO JAIMES ROLON	HOJA 16/37

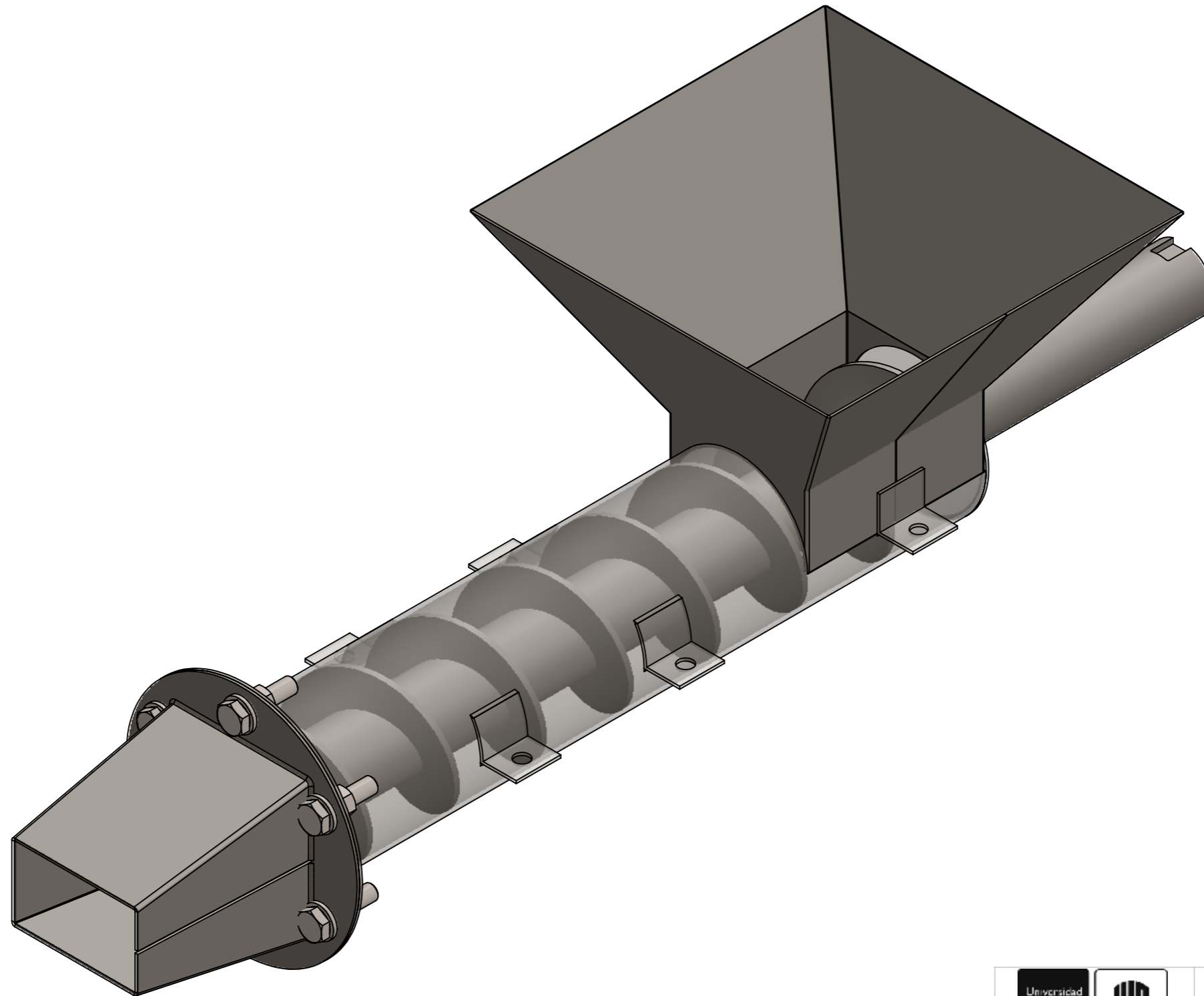

UNIVERSIDAD INDUSTRIAL DE SANTANDER

FECHA: 27/03/25

TITULO:
EXTRUSORA DE ARCILLA PARA LA PRODUCCIÓN EFICIENTE DE LADRILLOS, ISOMETRICA SUBSISTEMA DE EXTRUSIÓN

ESCALA: 1:4

DIBUJADO POR: ERIKA TATIANA SANTOS TOLOZA

UNIDADES: mm

PRESENTADO POR: ERIKA TATIANA SANTOS TOLOZA
JHON JAIRO SEPULVEDA CAMACHO

A3



DIRECTOR: RICARDO JAIMES ROLON

HOJA 17/37

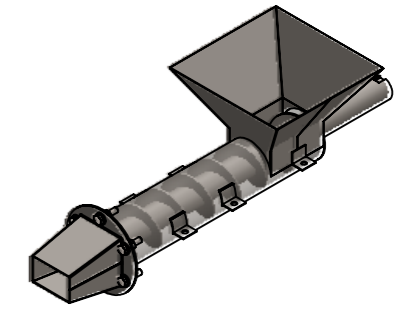

ESCALA 1:20

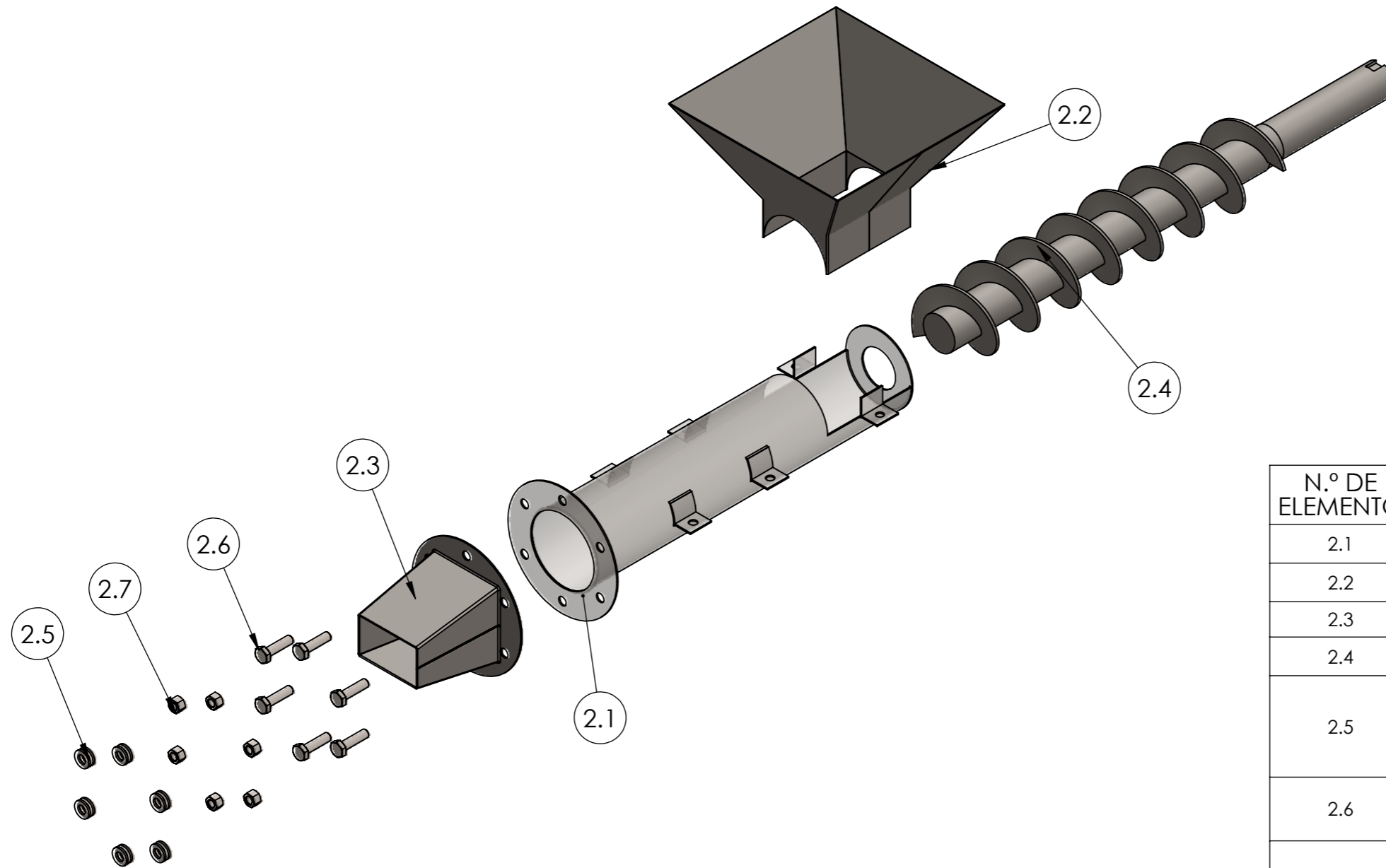

N.º DE ELEMENTO	N.º DE PIEZA	DESCRIPCIÓN	CANTIDAD
2.1	CILINDRO EXTRUSOR 1	ACERO AISI 1045	1
2.2	TOLVA DOBLADA 1	ACERO AISI 1045	1
2.3	BOQUILLA DOBLADA 1	ACERO AISI 1045	1
2.4	TORNILLO SIN FIN 1	ACERO AISI 4130	1
2.5	Washer ISO 7415 - 16	ACERO AL CARBONO TEMPLADO Y REVENIDO NORMA ISO 7415	12
2.6	TORNILLO HEXAGONAL M16 X 60, GRADO C	ACERO AL CARBONO ISO 7412	6
2.7	ISO - 4034 - M16 - N	ACERO AL CARBONO ISO 4034	6



UNIVERSIDAD INDUSTRIAL DE SANTANDER

FECHA: 27/03/25

TITULO:
EXTRUSORA DE ARCILLA PARA LA PRODUCCIÓN EFICIENTE
DE LADRILLOS, EXPLOSIONADO SUBSISTEMA DE EXTRUSIÓN

ESCALA: 1:9

DIBUJADO POR: ERIKA TATIANA SANTOS TOLOZA

UNIDADES: mm

PRESENTADO POR: ERIKA TATIANA SANTOS TOLOZA
JHON JAIRÓ SEPULVEDA CAMACHO

A3



DIRECTOR: RICARDO JAIMES ROLÓN

HOJA 18/37

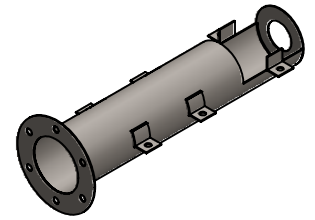
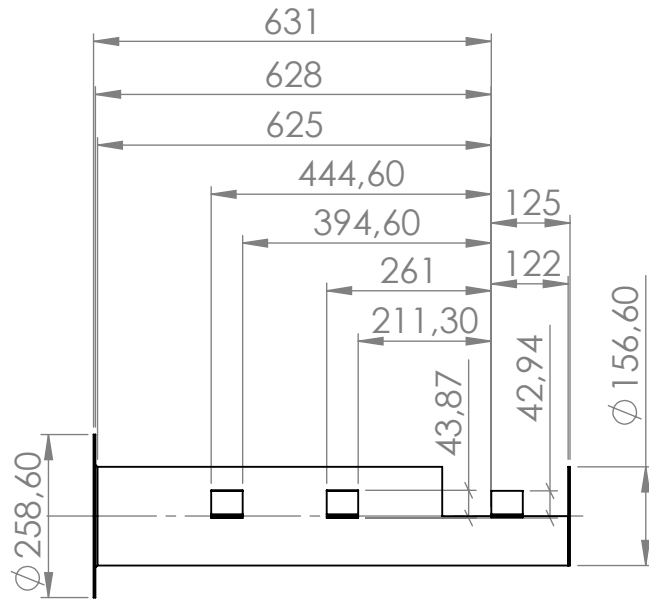

ESCALA 1:18

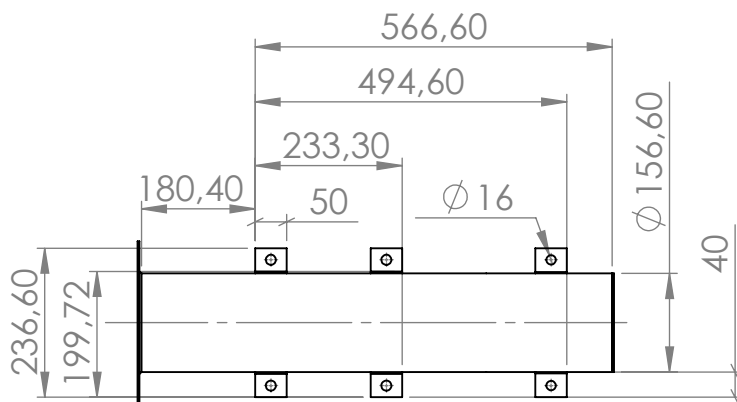
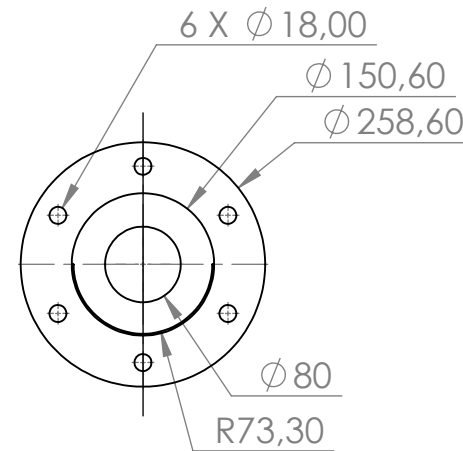

		UNIVERSIDAD INDUSTRIAL DE SANTANDER	
FECHA: 27/03/25		TITULO: EXTRUSORA DE ARCILLA PARA LA PRODUCCIÓN EFICIENTE DE LADRILLOS, PLANO DE PIEZA CÓDIGO DE PIEZA: 2.1 CILINDRO EXTRUSOR 1	
ESCALA: 1:12		DIBUJADO POR: ERIKA TATIANA SANTOS TOLOZA	
UNIDADES: mm		PRESENTADO POR: ERIKA TATIANA SANTOS TOLOZA JHON JAIRO SEPULVEDA CAMACHO	
A4		DIRECTOR: RICARDO JAIMES ROLON	HOJA 19/37

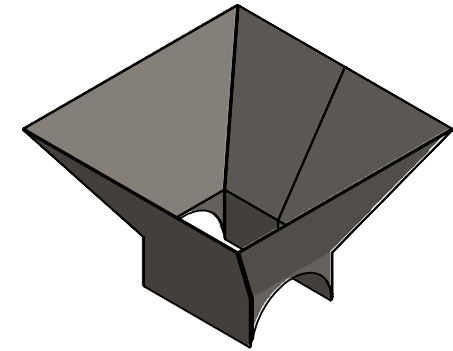
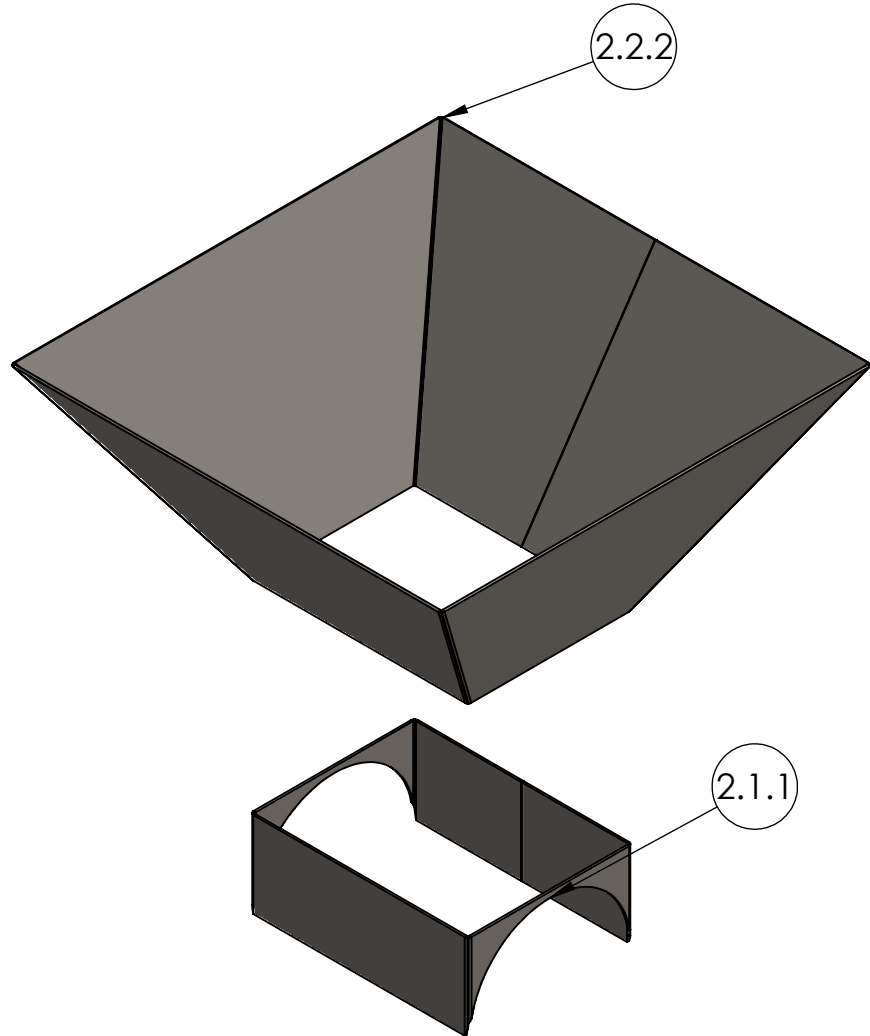

ESCALA 1:10

N.º DE ELEMENTO	N.º DE PIEZA	DESCRIPCIÓN	CANTIDAD
2.2.1	BASE TOLVA DOBLADA	ACERO AISI 1045	1
2.2.2	TOLVA DOBLADA	ACERO AISI 1045	1



UNIVERSIDAD INDUSTRIAL DE SANTANDER

FECHA: 27/03/25

TÍTULO: EXTRUSORA DE ARCILLA PARA LA PRODUCCIÓN EFICIENTE DE LADRILLOS, PLANO DE PIEZA
CÓDIGO DE PIEZA: 2.2 TOLVA DOBLADA 1

ESCALA: 1:5

DIBUJADO POR: ERIKA TATIANA SANTOS TOLOZA

UNIDADES: mm

PRESENTADO POR: ERIKA TATIANA SANTOS TOLOZA
JHON JAIRO SEPULVEDA CAMACHO

A4

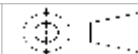

DIRECTOR: RICARDO JAIMES ROLON

HOJA 20/37

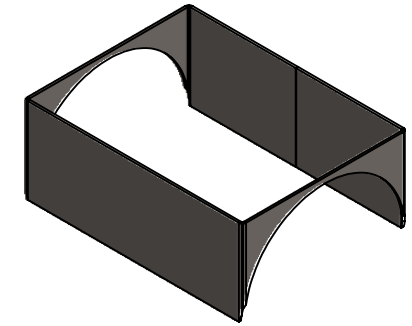
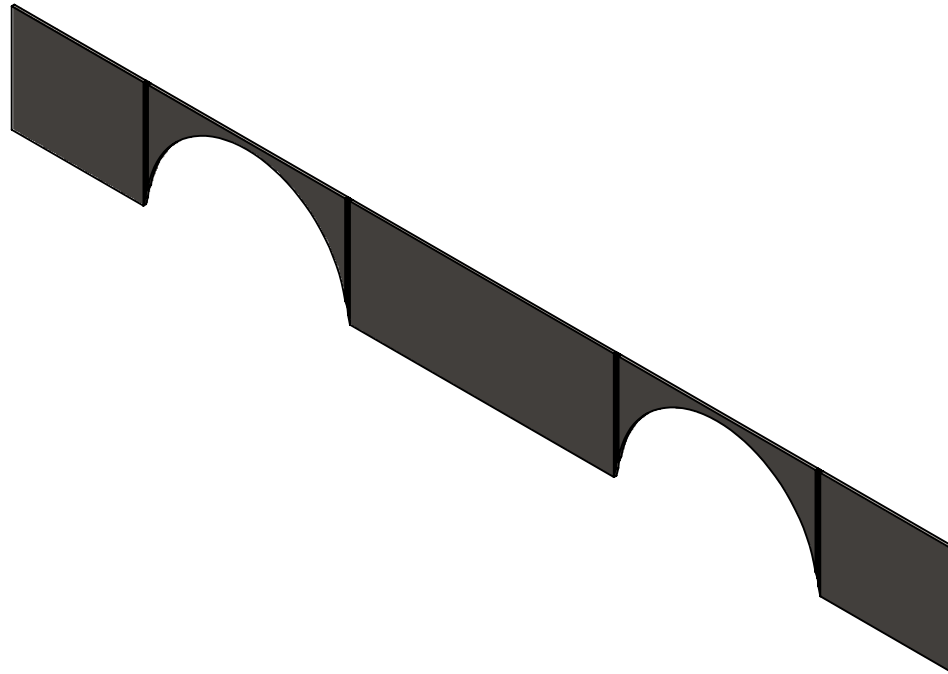

ESCALA 1:5

 		UNIVERSIDAD INDUSTRIAL DE SANTANDER	
FECHA: 27/03/25		TITULO: EXTRUSORA DE ARCILLA PARA LA PRODUCCIÓN EFICIENTE DE LADRILLOS, PLANO DE PIEZA CÓDIGO DE PIEZA: 2.2.1 BASE TOLVA DESDOBLADA	
ESCALA: 1:4		DIBUJADO POR: ERIKA TATIANA SANTOS TOLOZA	
UNIDADES: mm		PRESENTADO POR: ERIKA TATIANA SANTOS TOLOZA JHON JAIRO SEPULVEDA CAMACHO	
A4		DIRECTOR: RICARDO JAIMES ROLON	HOJA 21/37

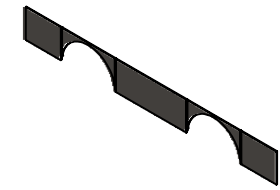

ESCALA 1:15

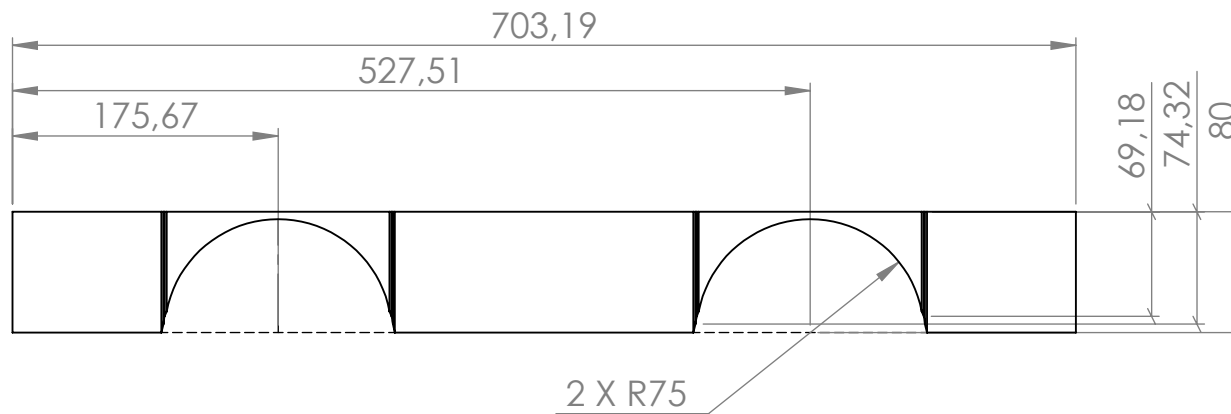

 		UNIVERSIDAD INDUSTRIAL DE SANTANDER	
FECHA: 27/03/25		TITULO: EXTRUSORA DE ARCILLA PARA LA PRODUCCIÓN EFICIENTE DE LADRILLOS, PLANO DE PIEZA CÓDIGO DE PIEZA: 2.2.1 BASE TOLVA DESDOBLADA	
ESCALA: 1:5		DIBUJADO POR: ERIKA TATIANA SANTOS TOLOZA	
UNIDADES: mm		PRESENTADO POR: ERIKA TATIANA SANTOS TOLOZA JHON JAIRO SEPULVEDA CAMACHO	
A4		DIRECTOR: RICARDO JAIMES ROLON	HOJA 22/37

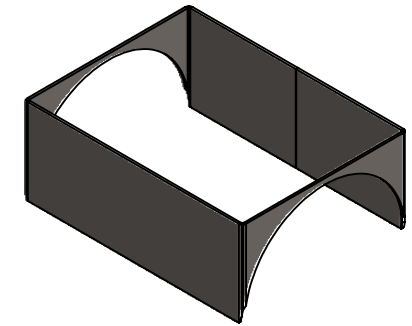
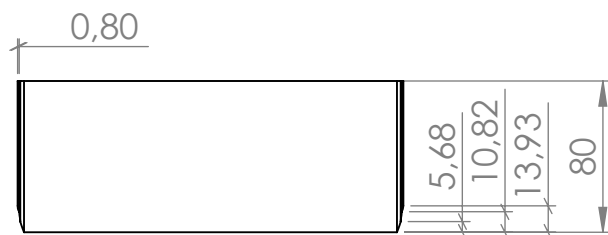
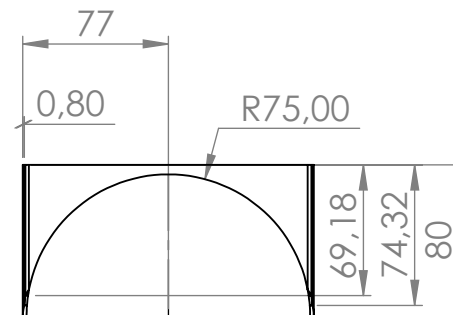
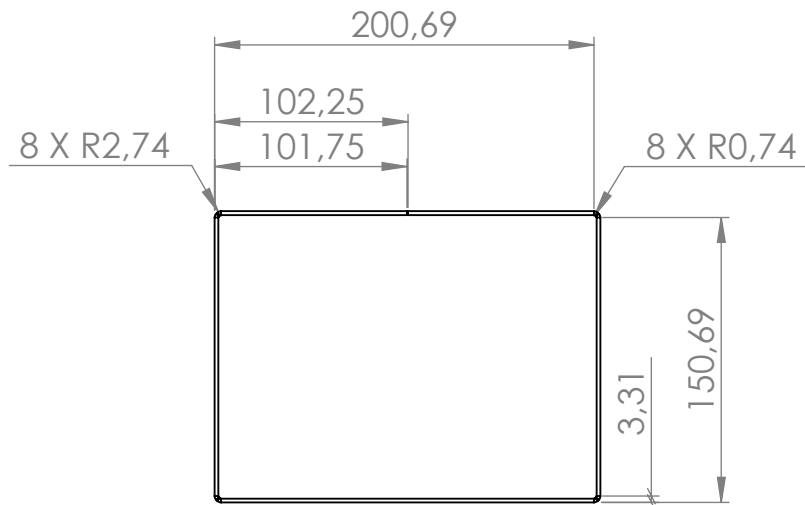

ESCALA 1:5

 		UNIVERSIDAD INDUSTRIAL DE SANTANDER	
FECHA: 27/03/25		TITULO: EXTRUSORA DE ARCILLA PARA LA PRODUCCIÓN EFICIENTE DE LADRILLOS, PLANO DE PIEZA CÓDIGO DE PIEZA: 2.2.1 BASE TOLVA DOBLADA	
ESCALA: 1:4		DIBUJADO POR: ERIKA TATIANA SANTOS TOLOZA	
UNIDADES: mm		PRESENTADO POR: ERIKA TATIANA SANTOS TOLOZA JHON JAIRO SEPULVEDA CAMACHO	
A4		DIRECTOR: RICARDO JAIMES ROLON	HOJA 23/37

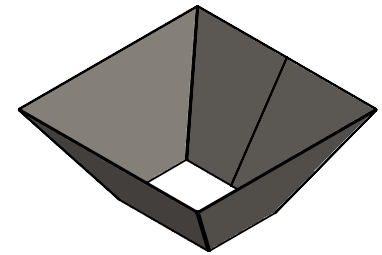
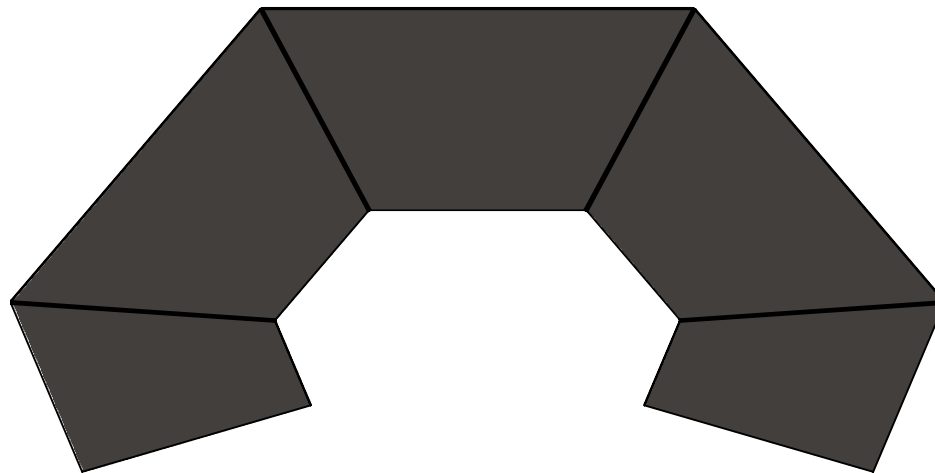

ESCALA 1:12

 		UNIVERSIDAD INDUSTRIAL DE SANTANDER	
FECHA: 27/03/25		TITULO: EXTRUSORA DE ARCILLA PARA LA PRODUCCIÓN EFICIENTE DE LADRILLOS, PLANO DE PIEZA CÓDIGO DE PIEZA: 2.2.2 TOLVA DESDOBLADA	
ESCALA: 1:7		DIBUJADO POR: ERIKA TATIANA SANTOS TOLOZA	
UNIDADES: mm		PRESENTADO POR: ERIKA TATIANA SANTOS TOLOZA JHON JAIRO SEPULVEDA CAMACHO	
A4		DIRECTOR: RICARDO JAIMES ROLON	HOJA 24/37

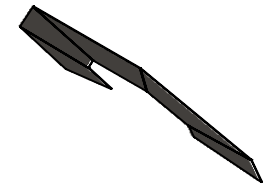
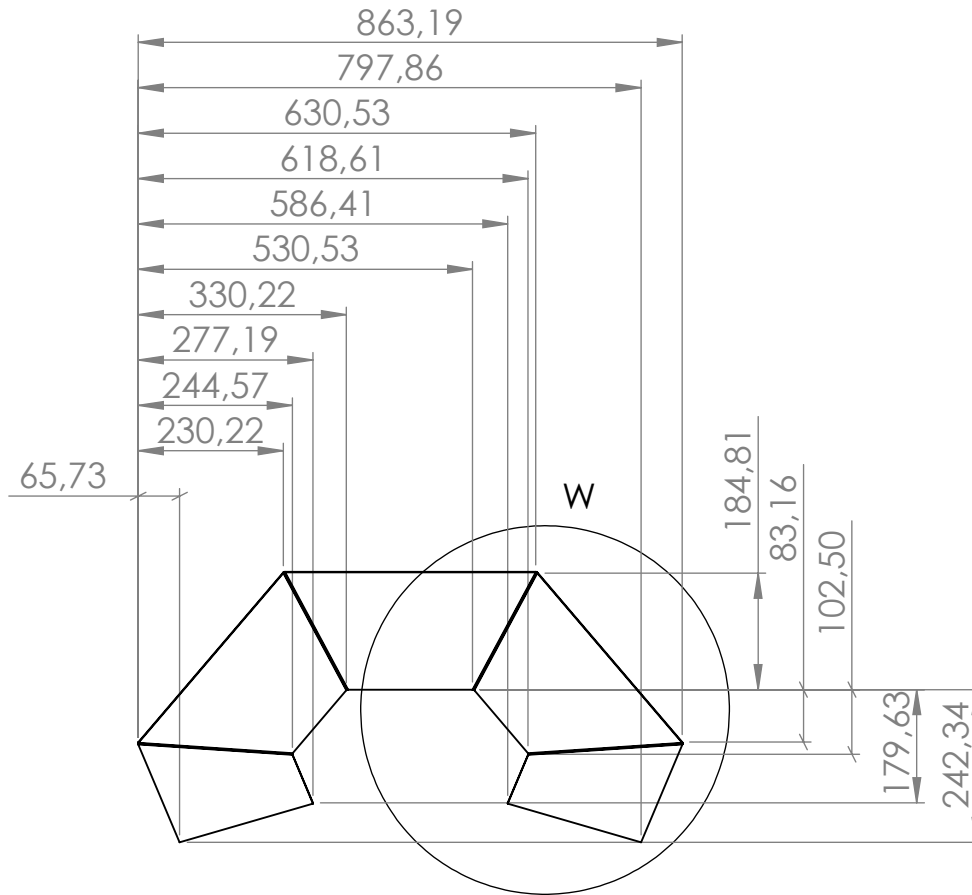

ESCALA 1:20

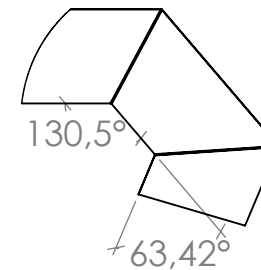

DETALLE W
ESCALA 1 : 15

 		UNIVERSIDAD INDUSTRIAL DE SANTANDER	
FECHA: 27/03/25		TITULO: EXTRUSORA DE ARCILLA PARA LA PRODUCCIÓN EFICIENTE DE LADRILLOS, PLANO DE PIEZA CÓDIGO DE PIEZA: 2.2.2 TOLVA DESDOBLADA	
ESCALA: 1:12		DIBUJADO POR: ERIKA TATIANA SANTOS TOLOZA	
UNIDADES: mm		PRESENTADO POR: ERIKA TATIANA SANTOS TOLOZA JHON JAIRO SEPULVEDA CAMACHO	
A4		DIRECTOR: RICARDO JAIMES ROLON	HOJA 25/37

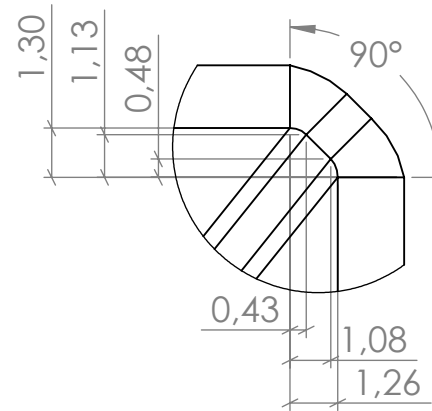
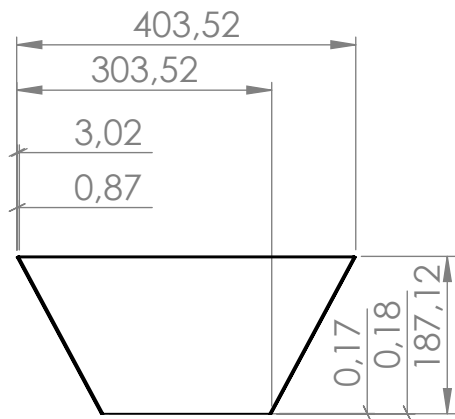
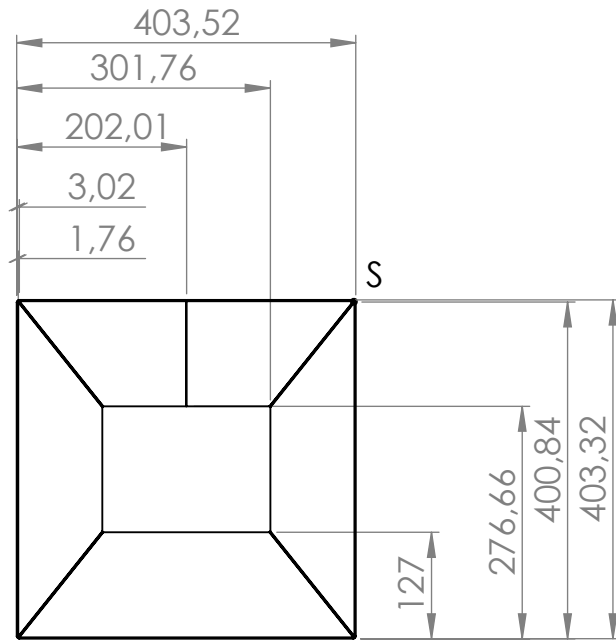

DETALLE S
ESCALA 5 : 1

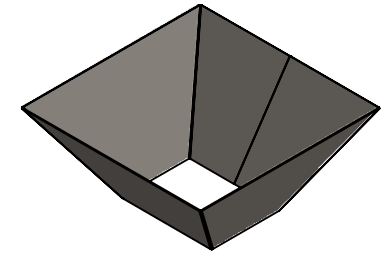

ESCALA 1:12

 		UNIVERSIDAD INDUSTRIAL DE SANTANDER	
FECHA: 27/03/25		TITULO: EXTRUSORA DE ARCILLA PARA LA PRODUCCIÓN EFICIENTE DE LADRILLOS, PLANO DE PIEZA CÓDIGO DE PIEZA: 2.2.2 TOLVA DOBLADA	
ESCALA: 1:9		DIBUJADO POR: ERIKA TATIANA SANTOS TOLOZA	
UNIDADES: mm		PRESENTADO POR: ERIKA TATIANA SANTOS TOLOZA JHON JAIRO SEPULVEDA CAMACHO	
A4		DIRECTOR: RICARDO JAIMES ROLON	HOJA 26/37

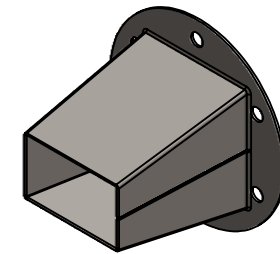
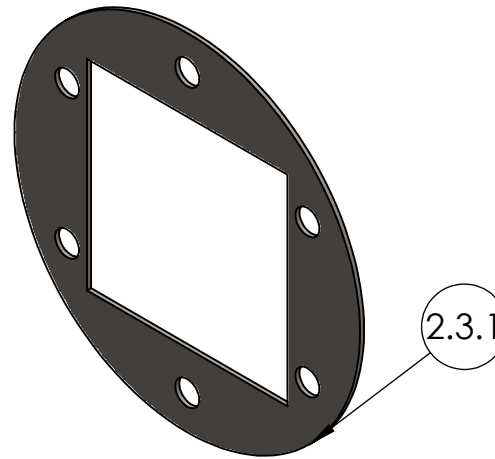
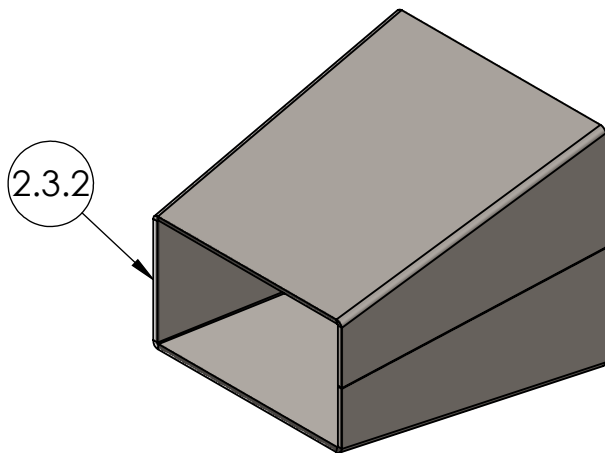

ESCALA 1:5

N.º DE ELEMENTO	N.º DE PIEZA	DESCRIPCIÓN	CANTIDAD
2.3.1	BASE DE BOQUILLA	ACERO AISI 1045	1
2.3.2	BOQUILLA DOBLADA	ACERO AISI 1045	1



UNIVERSIDAD INDUSTRIAL DE SANTANDER

FECHA: 27/03/25

TÍTULO: EXTRUSORA DE ARCILLA PARA LA PRODUCCIÓN EFICIENTE DE LADRILLOS, PLANO DE PIEZA
CÓDIGO DE PIEZA: 2.3 BOQUILLA DOBLADA 1

ESCALA: 1:4

DIBUJADO POR: ERIKA TATIANA SANTOS TOLOZA

UNIDADES: mm

PRESENTADO POR: ERIKA TATIANA SANTOS TOLOZA
JHON JAIRO SEPULVEDA CAMACHO

A4

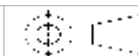

DIRECTOR: RICARDO JAIMES ROLON

HOJA 27/37

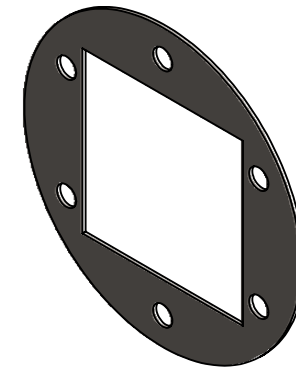
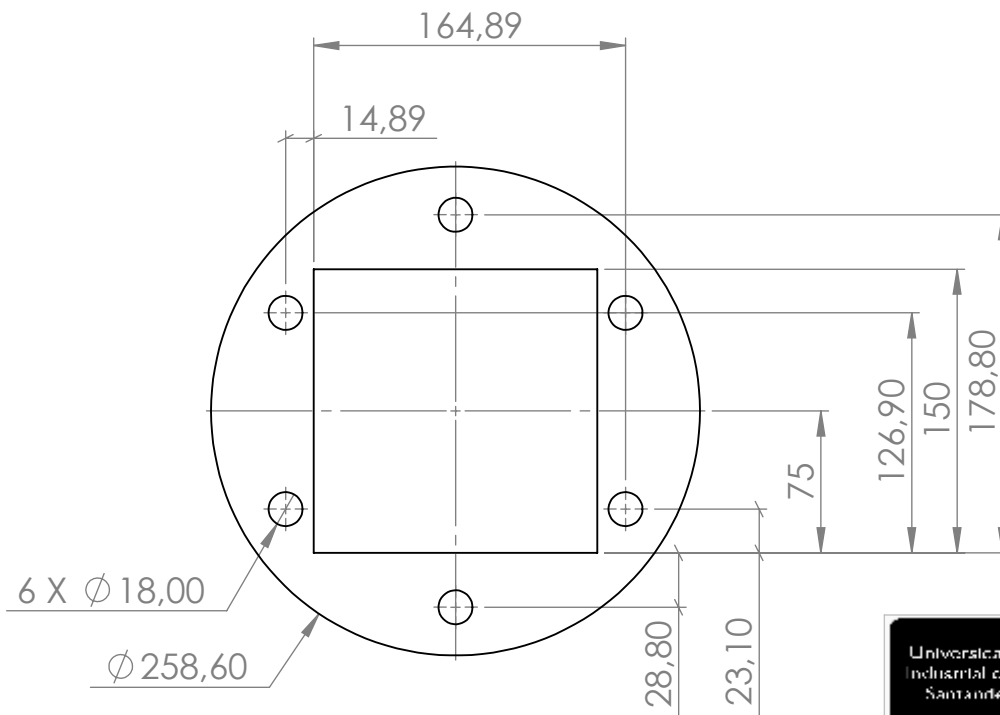

ESCALA 1:5

 		UNIVERSIDAD INDUSTRIAL DE SANTANDER	
FECHA: 27/03/25		TITULO: EXTRUSORA DE ARCILLA PARA LA PRODUCCIÓN EFICIENTE DE LADRILLOS, PLANO DE PIEZA CÓDIGO DE PIEZA: 2.3.1 BASE BOQUILLA	
ESCALA: 1:4		DIBUJADO POR: ERIKA TATIANA SANTOS TOLOZA	
UNIDADES: mm		PRESENTADO POR: ERIKA TATIANA SANTOS TOLOZA JHON JAIRO SEPULVEDA CAMACHO	
A4		DIRECTOR: RICARDO JAIMES ROLON	HOJA 28/37

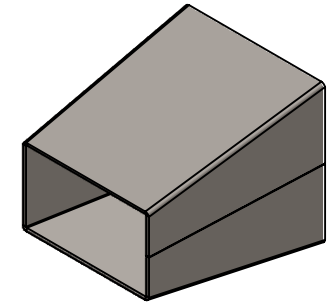
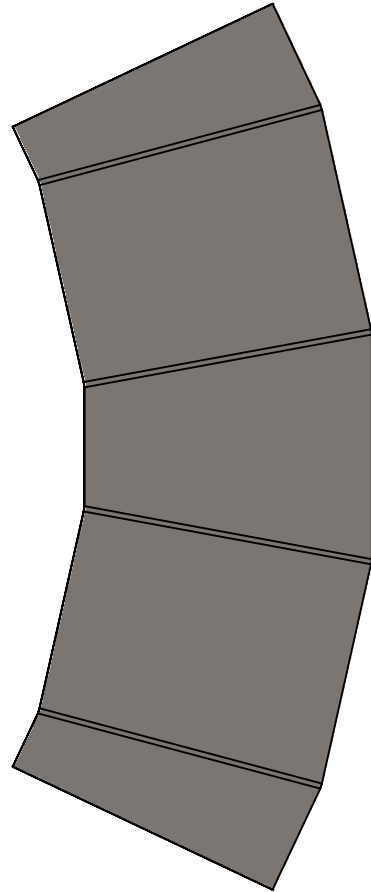

ESCALA 1:6

 		UNIVERSIDAD INDUSTRIAL DE SANTANDER	
FECHA: 27/03/25		TITULO: EXTRUSORA DE ARCILLA PARA LA PRODUCCIÓN EFICIENTE DE LADRILLOS, PLANO DE PIEZA CÓDIGO DE PIEZA: 2.3.2 BOQUILLA DESDOBLADA	
ESCALA: 1:5		DIBUJADO POR: ERIKA TATIANA SANTOS TOLOZA	
UNIDADES: mm		PRESENTADO POR: ERIKA TATIANA SANTOS TOLOZA JHON JAIRO SEPULVEDA CAMACHO	
A4		DIRECTOR: RICARDO JAIMES ROLON	HOJA 29/37

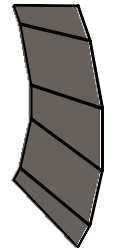
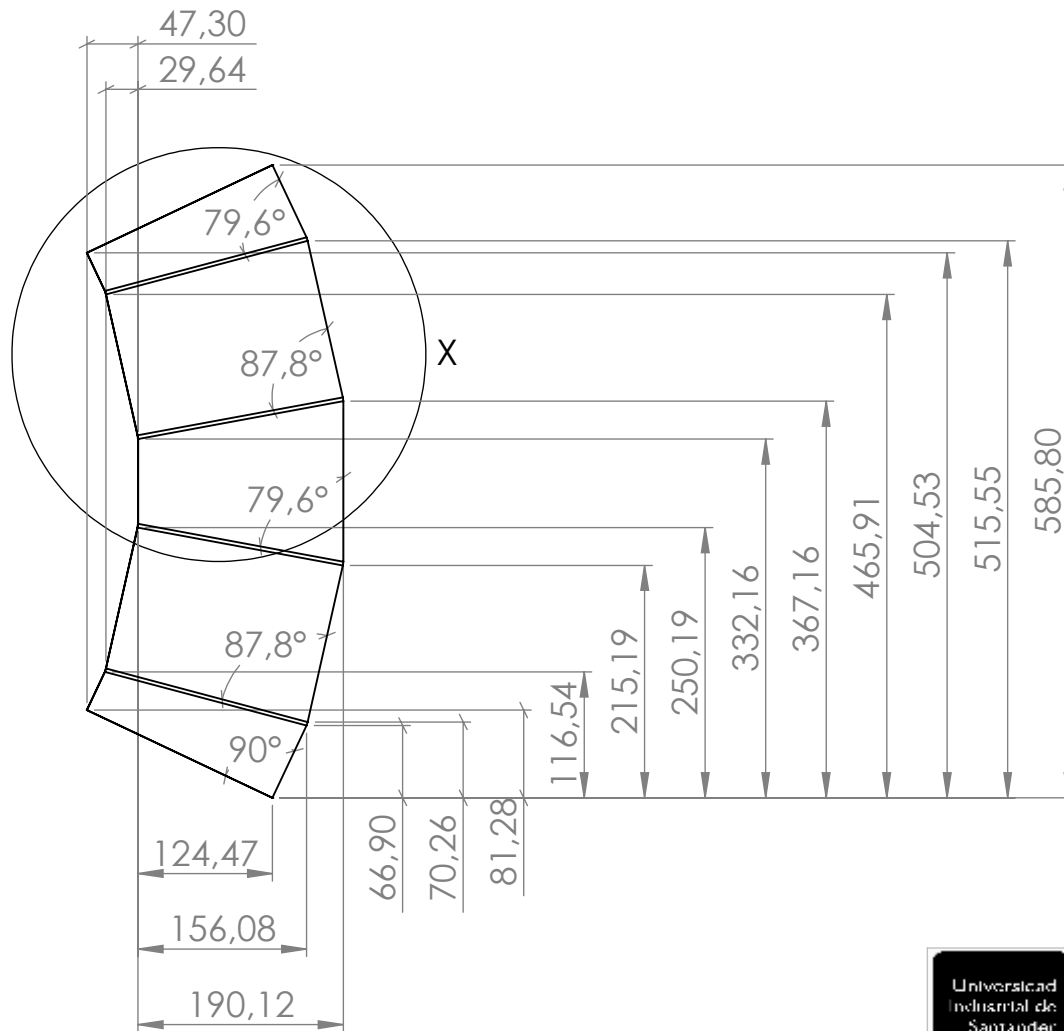

ESCALA 1:15

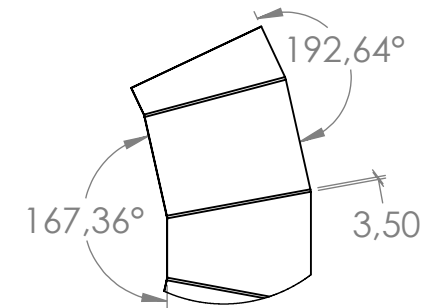

DETALLE X
ESCALA 1 : 10

 		UNIVERSIDAD INDUSTRIAL DE SANTANDER	
FECHA: 27/03/25		TITULO: EXTRUSORA DE ARCILLA PARA LA PRODUCCIÓN EFICIENTE DE LADRILLOS, PLANO DE PIEZA CÓDIGO DE PIEZA: 2.3.2 BOQUILLA DESDOBLADA	
ESCALA: 1:7		DIBUJADO POR: ERIKA TATIANA SANTOS TOLOZA	
UNIDADES: mm		PRESENTADO POR: ERIKA TATIANA SANTOS TOLOZA JHON JAIRO SEPULVEDA CAMACHO	
A4		DIRECTOR: RICARDO JAIMES ROLON	HOJA 30/37

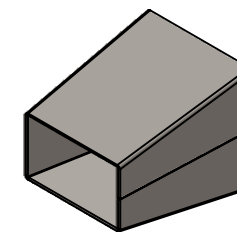
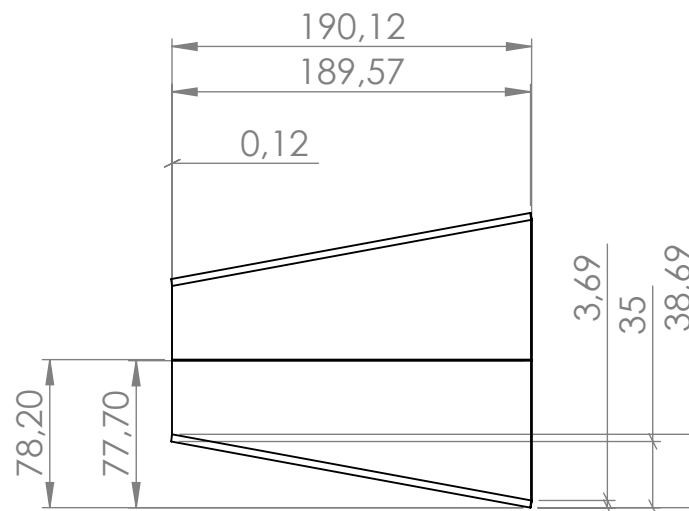
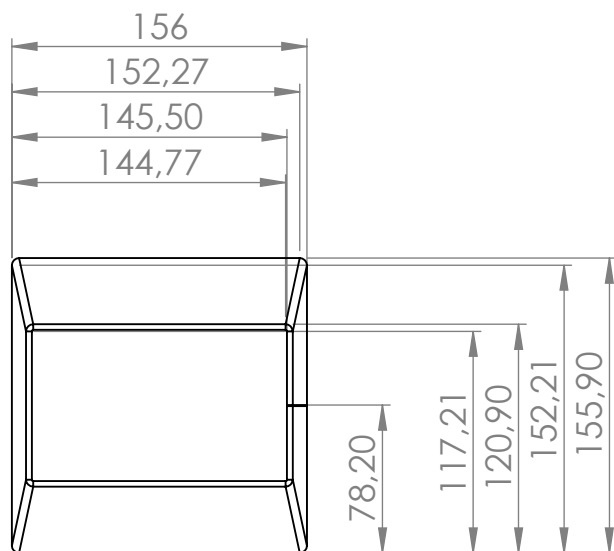
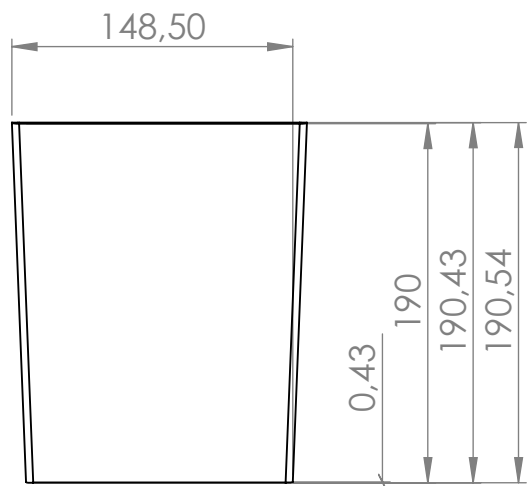

ESCALA 1:6



UNIVERSIDAD INDUSTRIAL DE SANTANDER

FECHA: 27/03/25

TITULO: EXTRUSORA DE ARCILLA PARA LA PRODUCCIÓN EFICIENTE DE LADRILLOS, PLANO DE PIEZA
CÓDIGO DE PIEZA: 2.3.2 BOQUILLA DOBLADA

ESCALA: 1:4

DIBUJADO POR: ERIKA TATIANA SANTOS TOLOZA

UNIDADES: mm

PRESENTADO POR: ERIKA TATIANA SANTOS TOLOZA
JHON JAIRO SEPULVEDA CAMACHO

A4

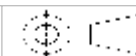

DIRECTOR: RICARDO JAIMES ROLON

HOJA 31/37

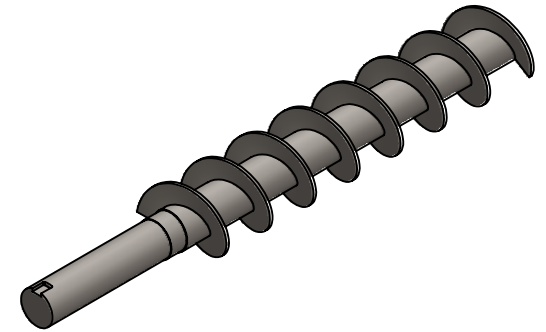
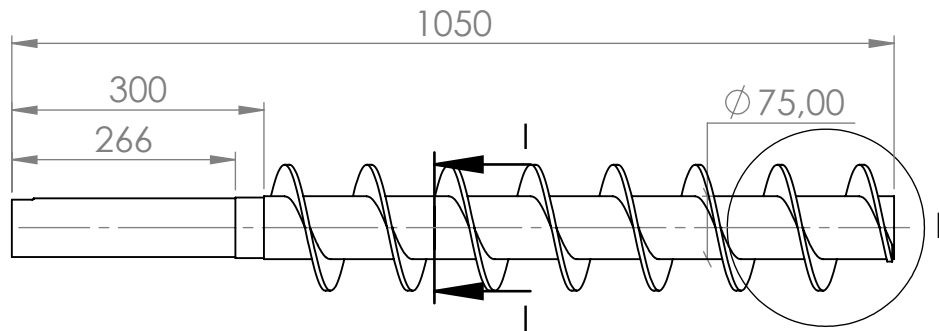

ESCALA 1:9

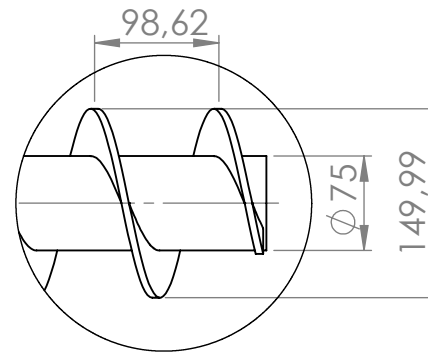
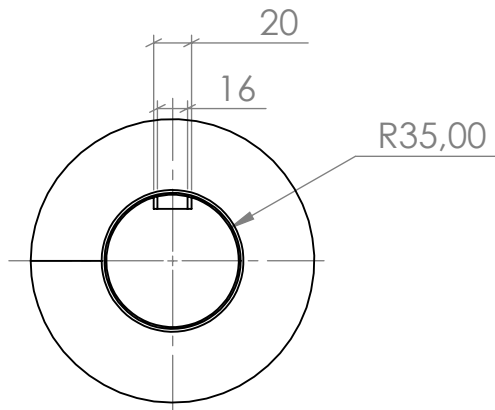

DETALLE L
ESCALA 1 : 6

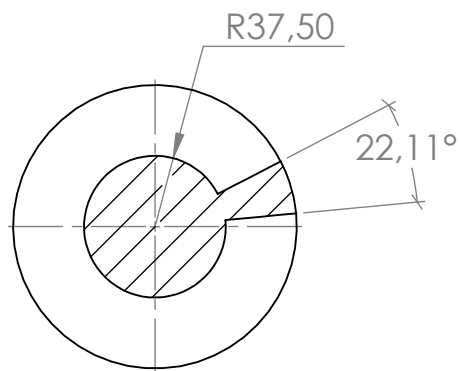

SECCIÓN II-II
ESCALA 1 : 4

 		UNIVERSIDAD INDUSTRIAL DE SANTANDER	
FECHA: 27/03/25		TITULO: EXTRUSORA DE ARCILLA PARA LA PRODUCCIÓN EFICIENTE DE LADRILLOS, PLANO DE PIEZA CÓDIGO DE PIEZA: 2.4 TORNILLO SIN FIN 1	
ESCALA: 1:9		DIBUJADO POR: ERIKA TATIANA SANTOS TOLOZA	
UNIDADES: mm		PRESENTADO POR: ERIKA TATIANA SANTOS TOLOZA JHON JAIRO SEPULVEDA CAMACHO	
A4		DIRECTOR: RICARDO JAIMES ROLON	HOJA 32/37



**UNIVERSIDAD INDUSTRIAL DE
SANTANDER**

FECHA: 27/03/25

TITULO:
EXTRUSORA DE ARCILLA PARA LA PRODUCCIÓN EFICIENTE
DE LADRILLOS, ISOMETRICA SUBSISTEMA SOPORTE BASTIDOR

ESCALA: 1:6

DIBUJADO POR: ERIKA TATIANA SANTOS TOLOZA

UNIDADES: mm

PRESENTADO POR: ERIKA TATIANA SANTOS TOLOZA
JHON JAIRO SEPULVEDA CAMACHO

A3



DIRECTOR: RICARDO JAIMES ROLON

HOJA 33/37

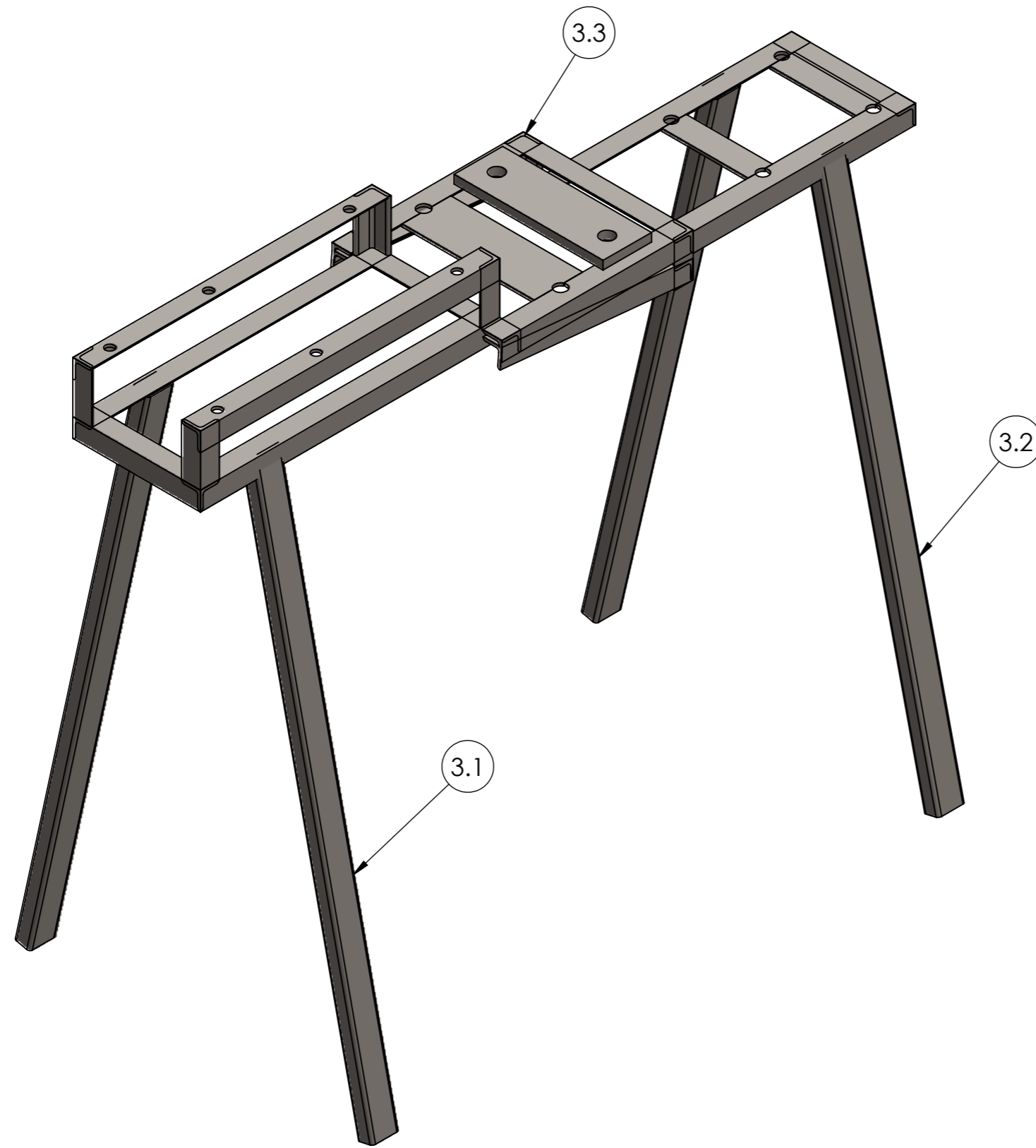

N.º DE ELEMENTO	N.º DE PIEZA	DESCRIPCIÓN	CANTIDAD
3.1	PIE DE SOPORTE	ACERO ASTM A36	1
3.2	VIGA DE REFUERZO INFERIOR	ACERO ASTM A36	1
3.3	BARRA HORIZONTAL SUPERIOR	ACERO ASTM A36	1



UNIVERSIDAD INDUSTRIAL DE SANTANDER

FECHA: 27/03/25

TITULO:
EXTRUSORA DE ARCILLA PARA LA PRODUCCIÓN EFICIENTE DE LADRILLOS, SUBSISTEMA SOPORTE DE BASTIDOR

ESCALA: 1:7

DIBUJADO POR: ERIKA TATIANA SANTOS TOLOZA

UNIDADES: mm

PRESENTADO POR: ERIKA TATIANA SANTOS TOLOZA
JHON JAIRO SEPULVEDA CAMACHO

A3



DIRECTOR: RICARDO JAIMES ROLON

HOJA 34/37

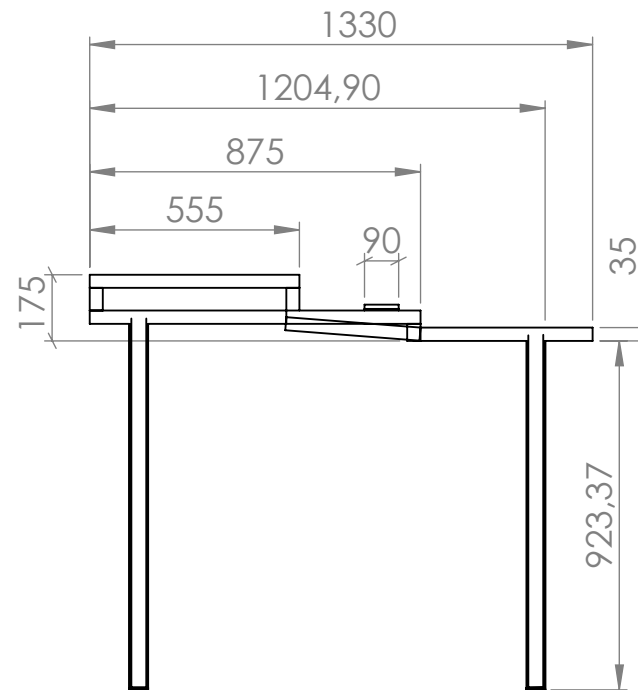
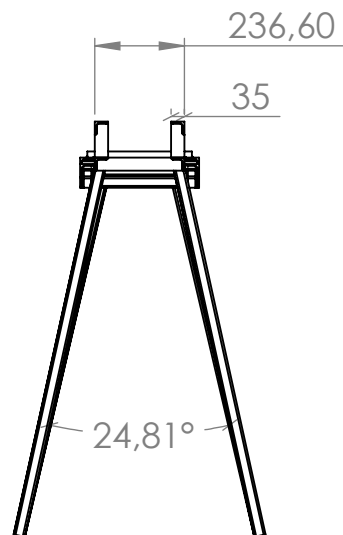
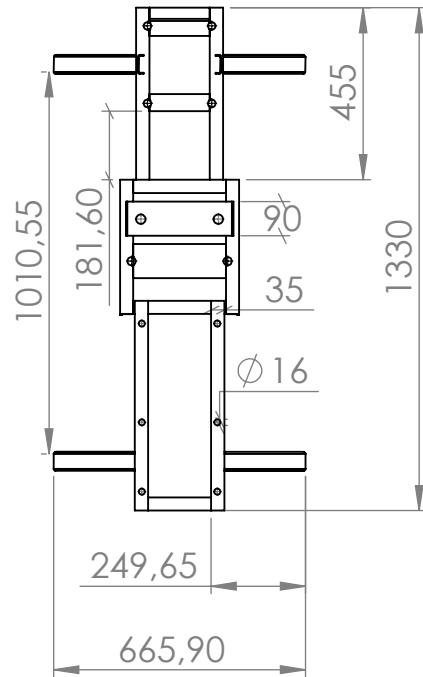

ESCALA 1:27

 		UNIVERSIDAD INDUSTRIAL DE SANTANDER	
FECHA: 27/03/25		TITULO: EXTRUSORA DE ARCILLA PARA LA PRODUCCIÓN EFICIENTE DE LADRILLOS, SOPORTE DE BASTIDOR	
ESCALA: 1:22		DIBUJADO POR: ERIKA TATIANA SANTOS TOLOZA	
UNIDADES: mm		PRESENTADO POR: ERIKA TATIANA SANTOS TOLOZA JHON JAIRO SEPULVEDA CAMACHO	
A4		DIRECTOR: RICARDO JAIMES ROLON	HOJA 35/37

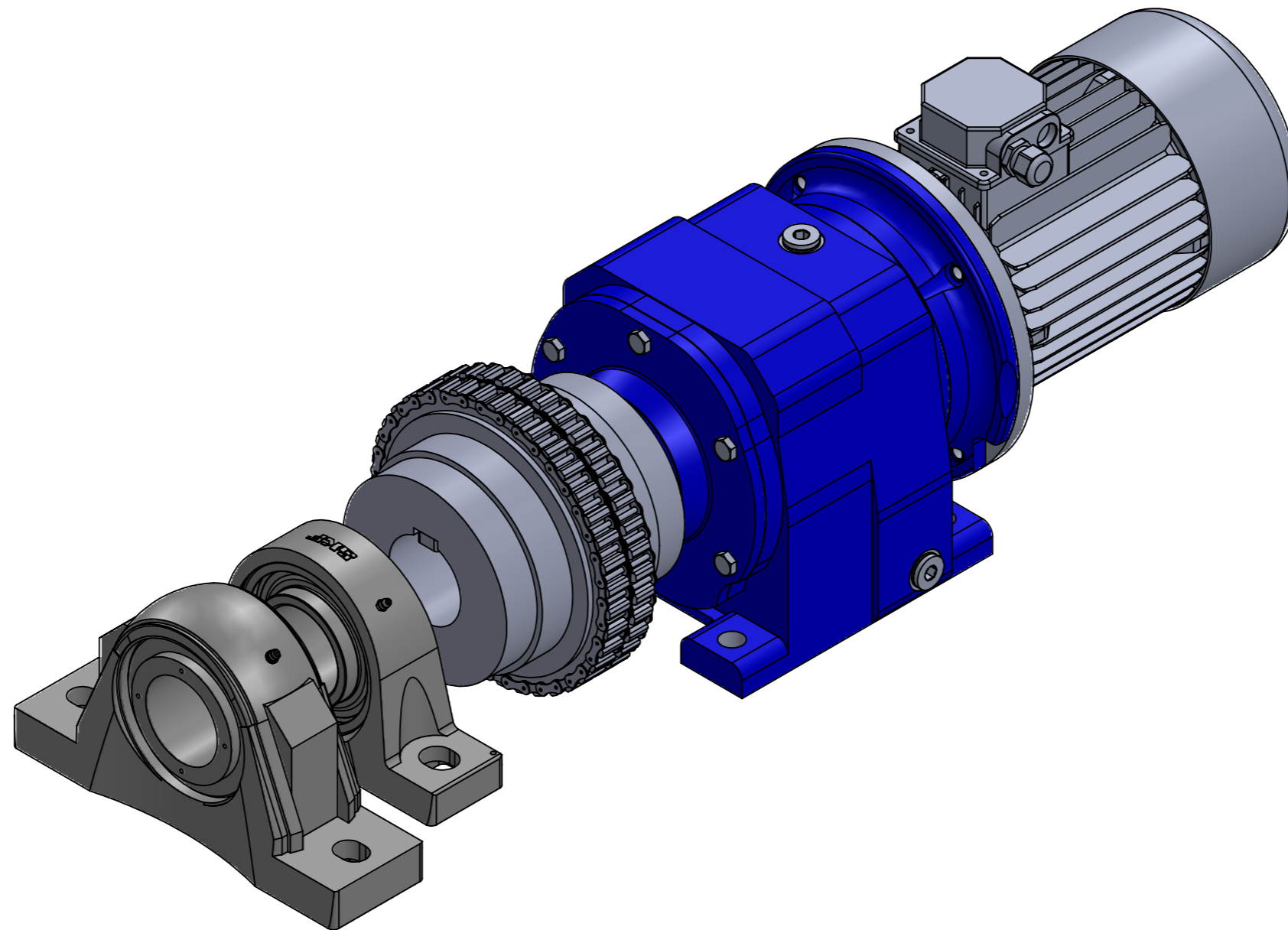

UNIVERSIDAD INDUSTRIAL DE SANTANDER

FECHA: 27/03/25

TITULO: EXTRUSORA DE ARCILLA PARA LA PRODUCCIÓN EFICIENTE DE LADRILLOS, ISOMETRICA SUBSISTEMA DE TRANSMICIÓN DE POTENCIA

ESCALA: 1:4

DIBUJADO POR: ERIKA TATIANA SANTOS TOLOZA

UNIDADES: mm

PRESENTADO POR: ERIKA TATIANA SANTOS TOLOZA
JHON JAIRO SEPULVEDA CAMACHO

A3



DIRECTOR: RICARDO JAIMES ROLON

HOJA 36/37

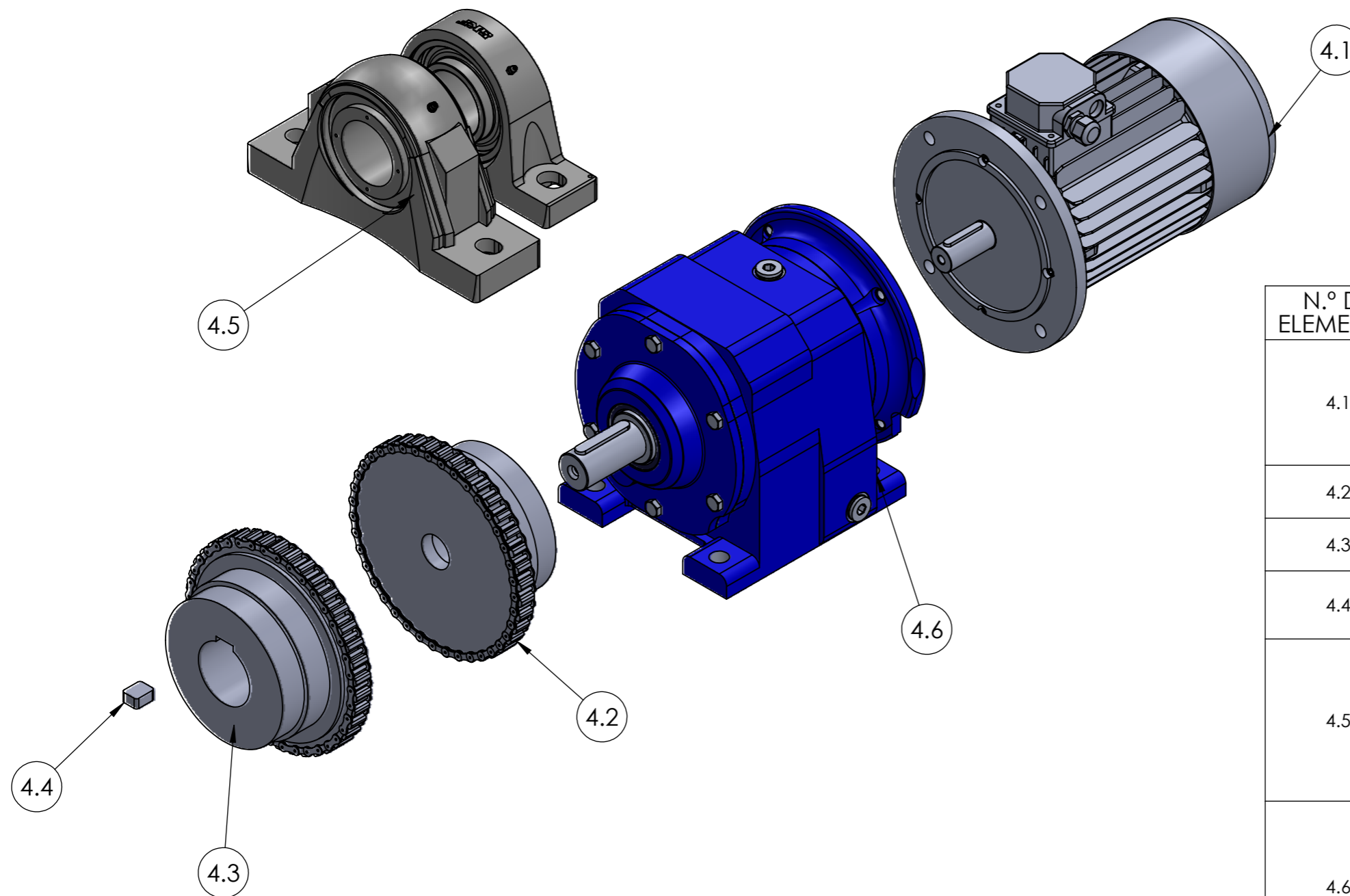

N.º DE ELEMENTO	N.º DE PIEZA	DESCRIPCIÓN	CANTIDAD
4.1	MOTOR ELÉCTRICO	DISPONIBLE EN: HTTPS://WWW.ELECTROMECANICAMM.COM.AR/PRODUCTO/MOTOR-ELECTRICO-TRIFASICO-MEC-3-HP-1500-RPM/8/#	1
4.2	ACOPLEREDUCTOR	INTERMEC S.A.	1
4.3	ACOPLERORNILLO	INTERMEC S.A.	1
4.4	CHAVETA RECTANGULAR 20 X 12	ACERO AISI 1045, TEMPLADO, CONFORME A ASME B17.1-1967	1
4.5	RODAMIENTOS	DISPONIBLE EN: HTTPS://WWW.SKF.COM/CO/PRODUCTS/MOUNTE D-BEARINGS/BALL-BEARING-UNITS/PILLOW-BLOCK-BALL-BEARING-UNITS/PRODUCTID-SYJ%2070%20TF	2
4.6	REDUCTOR DE VELOCIDAD	DISPONIBLE EN: HTTPS://AOKMANGROUP.EN.MADE-IN-CHINA.COM/PRODUCT/1-DVFNEYVALHE/CHINA-1-60-RATIO-SPEED-REDUCER-GEARBOX-USE-ALUMINUM-ALLOY-CASE-GEARBOX.HTML	1



UNIVERSIDAD INDUSTRIAL DE SANTANDER

FECHA: 27/03/25

TITULO: EXTRUSORA DE ARCILLA PARA LA PRODUCCIÓN EFICIENTE DE LADRILLOS, EXPLOSIONADO SUBSISTEMA DE TRANSMISIÓN DE POTENCIA

ESCALA: 1:25

DIBUJADO POR: ERIKA TATIANA SANTOS TOLOZA

UNIDADES: mm

PRESENTADO POR: ERIKA TATIANA SANTOS TOLOZA
JHON JAIRO SEPULVEDA CAMACHO

A3



DIRECTOR: RICARDO JAIMES ROLON

HOJA 37/37